



**Chest Freezer**

**USER MANUAL**

**MCH295W**





# CONTENTS

Safety information	.....	2-3
Identifying parts of the freezer	.....	4
Transporting	.....	5
Installation	.....	5
Operating instructions	.....	6
Defrosting	.....	7
Cleaning & Maintenance	.....	8
Energy saving tips	.....	9
Disconnection of the appliance	.....	9
Troubleshooting Guide	.....	10
Repairs, Service & Warranty	.....	11
Specifications	.....	12

# SAFETY INFORMATION

Congratulations on your new Midea freezer. This manual contains important information on the installation, use and care of your appliance. Please read this manual carefully before use. Follow instructions and keep the manual for future reference.

The appliance is specifically constructed for domestic use and is therefore suitable for the storage of frozen food and the production of ice-cubes. The appliance has not been designed or manufactured for professional use. Midea declines all responsibility for damage deriving from improper use of the appliance. The freezer has undergone the necessary tests on the tightness of the refrigeration circuit and complies with the safety regulations.



## WARNING

The WARNING symbol indicates information that concerns your personal safety



## CAUTION

The CAUTION symbol indicates information on avoiding damage to the appliance



## R600a WARNING LABEL

## R600a Refrigerant Warning



- This appliance contains a small quantity of flammable, non-synthetic R600a refrigerant.
- Ensure that the tubing of the refrigerant circuit is not damaged during transportation and installation.
- Ensure careful installing, handling and disposing to avoid safety hazards. If accidental damage occurs, keep the appliance away from open fires or devices that produce sparks, unplug the appliance and call an authorised service agent. Thoroughly ventilate the room in which the appliance is situated for several minutes.
- Leaking refrigerant may cause eye injuries or could ignite.
- Hydrocarbon refrigerants have excellent refrigerant properties, minimal global warming potential and no ozone depletion potential.
- Hydrocarbon refrigerants cannot be 'retrofitted' to an appliance that has not been designed and approved to use that type of refrigerant.
- The room for installing the appliance must be at least 1m<sup>3</sup> per 8g of refrigerant. The amount of refrigerant in the appliance can be found on the rating plate attached to the appliance.

# SAFETY INFORMATION

## Safety Precautions

- The freezer is designed to operate on a single phase power supply within a voltage range of 220-240V/50Hz.
- Do not allow any sharp objects to come in contact with the refrigerant system to avoid damage to the refrigerant circuit.
- This product is for indoor use only.
- Do not place electrical items or cooking equipment nearby. Keep away from substances which could cause ignition and ensure good ventilation is always available.
- Do not place or operate any electrical appliances inside the freezer.
- Do not place objects on top of the appliance which are magnetic, heavy or filled with water.
- If the supply cord is damaged, it must be replaced by authorised Midea service personal, service agent or similarly qualified persons in order to avoid a hazard.
- Do not store flammable, explosive, volatile and highly corrosive materials in the freezer. Containers with flammable gases or liquids can leak at low temperature. There is a risk of explosion or fire.
- Do not splash water on the appliance. It may cause malfunction or electric shock.
- Always switch off and unplug the appliance before cleaning.
- This appliance is not intended for use by persons (including children) with reduced physical, sensory or mental capabilities, or lack of experience and knowledge, unless they have been given supervision or instruction concerning use of the appliance by a person responsible for their safety.

## Safety of children



WARNING

- Young children should be supervised to ensure that they do not play with the appliance.
- Packing (e.g. plastic wraps, polystyrene etc.) can be dangerous for children. There is a risk of suffocation. Keep packaging materials away from children.

## Information on disposal

Most of the packing material used is recyclable. Please separate the plastic and cardboard and dispose through your local recycling depot or place in appropriate recycling collection bins.

If disposing of this appliance, please contact your local authority for safe disposal. Incorrect disposal may cause injury to the user or flammable gases may cause environmental damage. Remove the lid, cut off the main cable, break or remove spring or bolt catches to prevent children from getting trapped or harming themselves.

# IDENTIFYING PARTS OF THE FREEZER

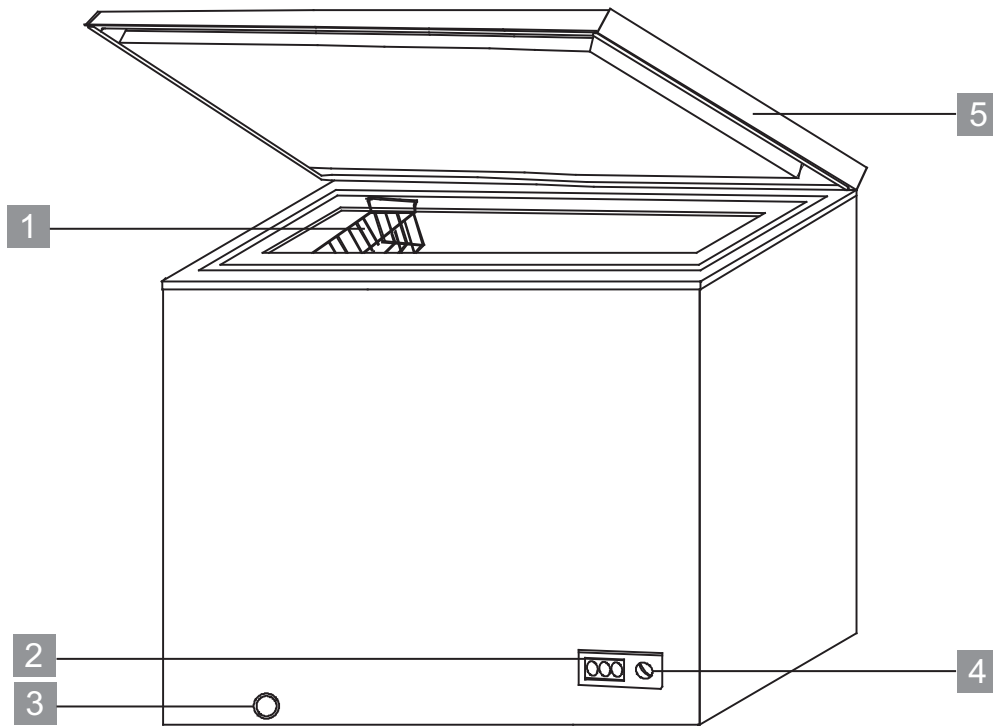

- 1 Wire basket
- 2 Light indicator
- 3 Drainage plug
- 4 Temperature control dial
- 5 Lid

# TRANSPORTING

Keep the freezer upright and avoid squeezing or vibration during transport. Avoid a slanting angle over 45 degrees during handling. Do not lift or pull the lid when moving, otherwise it may become deformed.

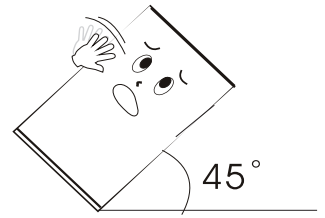

 Do not connect your freezer to the power supply immediately after it is placed vertically. You should keep it standing for at least 2 hours before connection to let it settle.

# INSTALLATION

Remove all packaging material and adhesive tape before using your new freezer. This includes the foam base and all adhesive tape holding the freezer accessories inside and outside.

Clean both the inside and outside of the freezer with a soft cloth and lukewarm soapy water.

## Positioning your freezer

Place your freezer in a well ventilated area away from a heat source and direct sunlight. Do not install the freezer in a damp or wet location as this may cause damage to the insulation and result in leakage. Condensation may also build up on the outer cabinet causing rust.

## Allow for adequate ventilation around your freezer

Allow 200mm of airspace between the back and sides of the freezer to allow for adequate air circulation. Ensure at least a 700mm clearance above the unit for the lid to fully open.

# OPERATING INSTRUCTIONS

## Controlling the temperature

The temperature of the freezer can be controlled manually by adjusting the temperature dial located on the front lower right hand corner (item 4 on page 4). The range of the temperature control is from position “1” the warmest to “6” the coldest. Adjust the temperature control to the setting that best suits your needs.

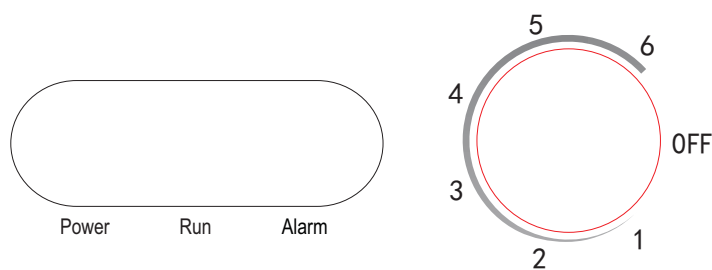

Position “4” is for normal use.

The “OFF” position stops the cooling cycle but does not shut off the power to the freezer.

## Lights

Green POWER light: Will always be on when the appliance is connected to the mains and switched on.

Red RUN light: Will be on when the compressor is working.

Red ALARM light: Will be on when the inside temperature is too high.

Note:

- The first time you turn the unit on, set the temperature dial to your desired position and allow the unit to cool down for 2~3 hours before placing food in the freezer.
- If you choose to change the temperature setting, adjust the dial by one numerical increment at a time. Allow several hours for the temperature to stabilise between adjustments.



## DEFROSTING

Heavy frost will effect the freezing process or internal temperature of the appliance and increase power consumption. Thus, defrosting is required if the frost is >5mm thick.

Defrosting is a manual process. Please follow these steps:

1. Turn the temperature dial to “OFF” (green light out) and disconnect the appliance.
2. Remove the frozen food from the freezer and place it in a cool area to protect the food. Remove the wire basket(s).
3. Open the lid and wait for the ice to defrost. During defrosting, the ice melts into the cabinet.
4. Remove the drain plug on the inside floor of the freezer by rotating it and pulling it out.
5. Place a shallow pan outside the drain outlet for the defrosted water to drain out into.
6. Check the pan occasionally so that the water does not overflow.
7. When defrosting, a plastic scraper or plastic utensil may be used. Never use metal instruments or electrical appliances to defrost the freezer.
8. When defrosting is complete, wipe down the inside of the freezer.
9. Replace the plug on inside floor.
10. Reset the temperature to the desired setting and power on the freezer.
11. Allow the cabinet to cool for at least one hour.
12. Return basket(s) and food to freezer.

**HELPFUL HINT:** Defrosting usually takes a few hours. Leaving the lid open will help speed the process. Also pouring warm water (not boiling) on the ice will help speed melting. If you must use a scraper - please use caution - it is very easy to damage the freezer compartment and void your warranty.

# CLEANING & MAINTENANCE

## Cleaning the appliance



**Before cleaning:** Turn appliance off at the power point, then remove the power cord from the outlet. This will make sure there is no chance of electric shock.

### Interior

Clean the freezer interior regularly. Turn power off. Wipe the interior with a soft cloth and lukewarm soapy water. Wipe away any food spills thoroughly. Dry all surfaces and removable parts. If you have taken out any removable parts, replace them and switch on the power before re-stocking the freezer.

### Exterior

Clean the freezer with only lukewarm soapy water and a soft cloth. Rinse with clean water and then wipe the surface with a soft clean cloth to remove any soap residue. Avoid getting water on the freezer controls.

### Lid seal

Take care to keep the lid seal clean. Sticky food and drink can cause the seal to stick to the cabinet and tear when you open the lid. Wash the seal with a mild detergent and warm water. Rinse thoroughly and dry.



Never use hot water, solvents, commercial kitchen cleaners, aerosol cleaners, metal polishers, caustic or abrasive cleaners or scourers to clean the appliance as they will damage it. Many commercially available cleaning products and detergents contain solvents that will damage your freezer. When cleaning, using only a soft cloth and lukewarm soapy water.

It is recommended that the freezer be cleaned each time it is defrosted to help keep the unit odour free and running efficiently.

## Please check the points below after maintenance:

- (1) Is there any damage to the power lead?
- (2) Can the power plug be inserted into the power socket correctly?
- (3) Is the power plug and/or lead heating up?

## ENERGY SAVING TIPS

1. Reduce opening the lid frequently. This will increase the appliance efficiency and reduce power consumption.
2. Be sure to wrap food properly, and wipe containers dry before placing them in the freezer. This cuts down on frost build-up inside the freezer.
3. There should always be some space between food items for proper air circulation.
4. Hot food should be cooled down before placing into the appliance, otherwise the interior temperature and power consumption will increase.
5. Adjust the temperature control to a setting that is acceptable for the storage of the food. This will reduce the power consumption.

## DISCONNECTION OF THE APPLIANCE



If unplugging the appliance from the power outlet, please leave at least 5 minutes before re-connection.

During a power failure, do not put additional food in the appliance and reduce opening the lid.

Leave the freezer operating during short vacations.

If the freezer will not be used for several months or it is to be placed in storage, remove all food and unplug the power cord. Clean and dry the interior thoroughly. To prevent odour and mould growth, leave the lid open slightly: wedging it open if necessary or have the lid removed.

Use extreme caution in the case of children. The unit should not be accessible to child's play.

# TROUBLESHOOTING GUIDE

If you think something may be wrong with your freezer, you can carry out some easy checks before calling for service. You may locate the problem and spare yourself from inconvenience, saving time and money.

<b>SYMPTOM</b>	<b>SUGGESTION</b>
Freezer is not operating	<ul style="list-style-type: none"><li>• Check that the power cord is plugged into the power outlet properly and that the outlet is switched “ON”.</li><li>• Try running another appliance from the power outlet. If no power is coming from the outlet you may have blown a fuse or tripped a circuit of your household power supply.</li><li>• Try adjusting the temperature control to a slightly “colder” position.</li><li>• The freezer temperature control is set at “OFF”.</li></ul>
Unusual noise	<ul style="list-style-type: none"><li>• The flow of refrigerant through the pipeline coil could cause gurgling, similar to water boiling. This is the normal function of the appliance.</li><li>• Metal parts undergo expansion and contraction, as in hot water pipes. This is normal. Sound will level off or disappear as freezer continues to run.</li><li>• It is quite normal for noise to seem louder just after the freezer starts operating.</li><li>• Other strange sounds may mean that you need to check and take action. For example, noises may mean that:<ul style="list-style-type: none"><li>– The cabinet is not level.</li><li>– The floor is uneven or weak.</li><li>– There are vibrations from an object on top of or behind or beside the freezer.</li><li>– The back of the freezer cabinet is touching the wall.</li></ul></li></ul>
Compressor seems to run more than expected	<ul style="list-style-type: none"><li>• Is lid kept open too long or too often?</li><li>• Is control set too cold?</li><li>• Have large amounts of warm food just recently been stored?</li><li>• If the day is hot or the room is very warm, the freezer will need to run more than normal.</li><li>• The freezer will run more than normal just after you install it or when it has been turned off for a long time.</li></ul>
Temperature in the freezer is too warm	<ul style="list-style-type: none"><li>• Check that the appliance has enough clearance at the sides, back and top. Refer to installation instruction on page 5.</li><li>• Refer to “Controlling the temperature” on page 6.</li><li>• You may have kept the lid open too long or too frequently.</li><li>• Food containers or packaging may be holding a lid open.</li></ul>
The lid will not close	<ul style="list-style-type: none"><li>• The seal is dirty.</li><li>• Check whether something is holding the lid open.</li></ul>

## The following cases are not malfunctions:

Moisture may form as condensation on the outside of the appliance during humid conditions. To remove excess moisture, wipe clean.

It is normal that the sides of the appliance and the turnover beam will get warm as a result of the refrigeration system operation.

The appliance operation could cause electrical interference to electrical equipment.

## **REPAIRS, SERVICE & WARRANTY**

It is hazardous for anyone installing, removing, altering, repairing servicing, testing or certifying the gas system of a gas device (i.e. charging, discharging or breaking into the refrigeration system that uses hydrocarbon refrigerants). Only an Authorised Service Person can carry out servicing or repairs to this appliance.

### **If service is required**

If you have a problem which persists after you have made the checks listed in the Troubleshooting Guide, please contact:

Midea Customer Care on 1300 132 371

Please refer to the enclosed warranty card or visit [www.mideaappliances.com.au](http://www.mideaappliances.com.au) for warranty information. Ensure you have the appliance model number and proof of purchase handy before calling Midea Customer Care to enquire about a warranty claim.

Complete and retain the following information for your records:

Model No.	
Serial No.	
Date of purchase	
Retailer	

**Please retain proof of purchase for warranty claims.**

# SPECIFICATIONS

Model	MCH295W	
Climate class	T	
Classification of installation and use	Class 1 Indoor use only	
Rated Total Gross Volume	295L	
Voltage	220-240V / 50 Hz	
Refrigerant type	R600a	
Dimensions	Height	850mm
	Width	1115mm
	Depth	670mm
IP rating	IPX0	
Net Weight	42Kg	

## NOTE:

- Product specifications are subject to change without prior notice.
- This product is subject to continuous improvement, which may not be completely consistent with the manual, however the functions and operating methods will not change.



