

Sunbeam ZUMBO

LIMITED EDITION

Food Processor
Instruction Booklet



Contents

Sunbeam's Safety Precautions	2
Features of your Zumbo Limited Edition Food Processor	3
Attachments for your Zumbo Limited Edition Food Processor	5
Using your Zumbo Limited Edition Food Processor	6
Fitting/using the tools on your Zumbo Limited Edition Food Processor	8
Storing your Zumbo Limited Edition Food Processor	10
Handy hints for processing	12
Care and cleaning	13

Important instructions – retain for future use.

تأكد من تفهم احتياطات السلامة المذكورة اعلاه

請務必理解上述的安全預防措施。

Assurez-vous que les précautions ci-dessus relatives à la sécurité sont bien comprises

Versichern Sie sich, dass die obenstehenden Sicherheitsmaßnahmen verstanden werden

Βεβαιώστε πως οι παραπάνω προφυλάξεις ασφαλείας γίνονται κατανοητές

Pastikan bahwa tindakan-tindakan keselamatan seperti di atas dimengerti anda

Accertatevi che le suddette norme di sicurezza siano comprese a dovere

上記の注意事項をよくお読みになり、安全を御確認ください

Уверете се дека погоре споменатите мерки на претпазливост се добро разбрани

Asegúrese de que las precauciones de seguridad precedentes sean bien comprendidas

کاری بکنید کہ احتیاط‌های بالا حتماً درک بشوند

ต้องแน่ใจว่า ข้อควรระวังเรื่องความปลอดภัยข้างต้น เป็นที่เข้าใจกันดี

Yukarda belirtilen güvenliğin önlemlerinin anlaşıldığından emin olunuz

Xin kiểm chắc rằng những biện pháp làm an toàn kể trên được hiểu rõ

Sunbeam's Safety Precautions

SAFETY PRECAUTIONS FOR YOUR SUNBEAM FOOD PROCESSOR LC9600Z.

- Always use extreme care when handling blades and cutting discs. These are extremely sharp and may cause injury if handled incorrectly. Always store blades and cutting discs in their respective covers or processing containers.
- Unplug from power outlet when not in use, before putting on or taking off attachments, and before cleaning.
- Do not put hot liquids into the processing bowl. Cool to room temperature before placing in processing bowl.
- Avoid contacting moving parts at all times.
- Place the processing bowl onto the base of the processor before fitting any attachments.

Sunbeam is very safety conscious when designing and manufacturing consumer products, but it is essential that the product user also exercise care when using an electrical appliance. Listed below are precautions which are essential for the safe use of an electrical appliance:

- Read carefully and save all the instructions provided with an appliance.
- Always turn the power off at the power outlet before you insert or remove a plug. Remove by grasping the plug - do not pull on the cord.
- Turn the power off and remove the plug when the appliance is not in use and before cleaning.
- Do not use your appliance with an extension cord unless this cord has been checked and tested by a qualified technician or service person.
- Always use your appliance from a power outlet of the voltage (A.C. only) marked on the appliance.
- This appliance is not intended for use by persons (including children) with reduced physical, sensory or mental capabilities, or lack of experience and knowledge, unless they have been given supervision or instruction concerning use of the appliance by a person responsible for their safety.
- Children should be supervised to ensure that they do not play with the appliance.
- The temperature of accessible surfaces may be high when the appliance is operating.
- Never leave an appliance unattended while in use.

If you have any concerns regarding the performance and use of your appliance, please visit www.sunbeam.com.au or contact the Sunbeam Consumer Service Line.

Ensure the above safety precautions are understood.

- All blades and attachments should be removed with care before cleaning.
- Potential injury from misuse.
- Do not over fill the processor.
- Do not process for longer than the time periods recommended in the operating chart.
- Always remove the blade before emptying the processing bowl of its contents.
- Do not operate for more than 30 seconds at a time when processing heavy loads. None of the recipes in this manual are considered a 'heavy load'.
- Take care when removing the bowl from the base, emptying the bowl or during fitting and removal of blade system, as blades are extremely sharp.

- Do not use an appliance for any purpose other than its intended use.
- Do not place an appliance on or near a hot gas flame, electric element or on a heated oven.
- Do not place on top of any other appliance.
- Do not let the power cord of an appliance hang over the edge of a table or bench top or touch any hot surface.
- Do not operate any electrical appliance with a damaged cord or after the appliance has been damaged in any manner. If damage is suspected, return the appliance to the nearest Sunbeam Appointed Service Centre for examination, repair or adjustment.
- For additional protection, Sunbeam recommend the use of a residual current device (RCD) with a tripping current not exceeding 30mA in the electrical circuit supplying power to your appliances.
- Do not immerse the appliance in water or any other liquid unless recommended.
- Appliances are not intended to be operated by means of an external timer or separate remote control system.
- This appliance is intended to be used in household and similar applications such as: staff kitchen areas in shops, offices and other working environments; farm houses; by clients in hotels, motels and other residential type environments; bed and breakfast type environments.

Features of your Zumbo Limited Edition Food Processor

Processing cover

The processing cover or lid of bowl provides a safety feature to the appliance. The appliance will not operate unless the bowl, cover and large feed pusher are correctly positioned and locked into place.

1400 watt induction motor

The die-cast base houses a powerful 1400 watt motor. This motor is ideal for high load applications during processing, and provides a greater starting strength whilst maintaining speed throughout. The Zumbo Limited Edition Food Processor motor is reliable, quiet, will provide a long life and is backed by a 10 year guarantee.

START/STOP button

For easy use the START/STOP button starts and stops the operation of the food processor.

Auto Pulse

The Auto Pulse function is a clever and versatile feature providing short bursts of processing, for a set length of time. Creating bread or biscuit crumbs couldn't be easier.

Pulse

The control panel includes a Pulse function for optimum cutting precision during processing.

Storage drawer

The unique drawer design enables attachments to be stored conveniently, and safely, within the appliance when not in use.

Non-slip feet

Keeps the food processor secure on the bench top during use.

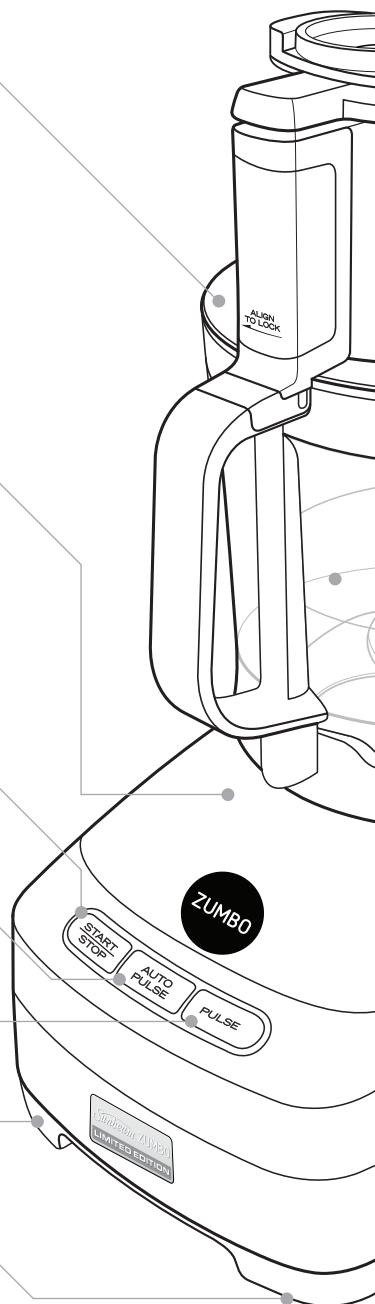

on

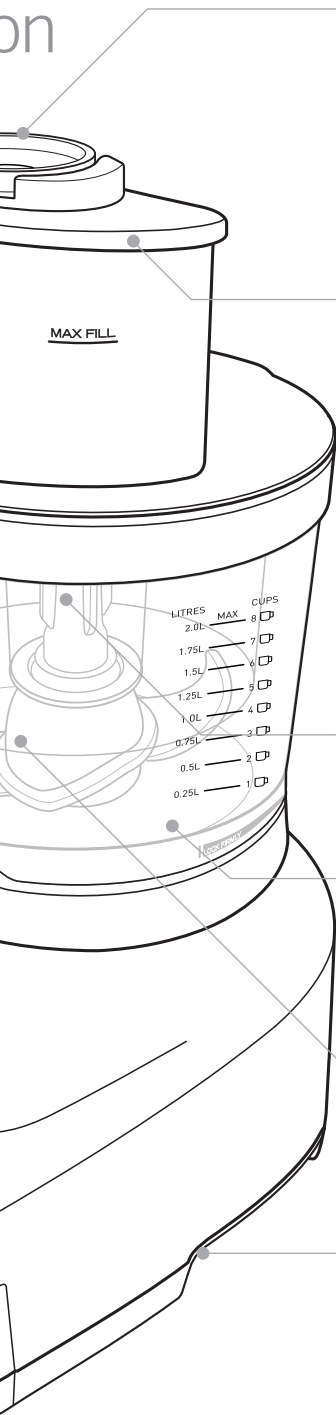

Food Pushers

The food pushers assist in guiding the food through the chute to ensure ingredients hit the blade vertically for best processing results. Three food pushers are included, depending on the size of the chute being used and the size of foods. For thinner foods, use the smaller internal pusher for consistent even slicing. This pusher also doubles as a measuring cup.

Wide Chute

At 14cm's wide, the extra wide chute eliminates the need to cut most ingredients, to fit into the chute. Guide ingredients through the chute into the selected blades. Additional ingredients can be added during other processing tasks.

Chute Safety Feature

The wide chute pusher provides a safety interlock feature to the appliance. The motor will not operate unless the bowl and lid are correctly locked in position, and the large feed pusher is inserted.

Spindle

Drives all the food processing attachments. The spindle must be in place to operate the food processor.

Processing bowl with handle

Large 2 litre capacity processing bowl. The handle of the processing bowl includes a patent-pending robust stainless steel interlock that prevents food catching and building up, ensuring easy cleaning.

Second processing bowl

The smaller processing bowl is ideal for small amounts of ingredients. At 400ml in volume, this bowl is perfect for chopping nuts, creating pesto or chopping herbs.

Cord storage facility

For added convenience the unused cord length can easily be pushed into the base of the processor for storage.

Attachments for your Zumbo Limited Edition Food Processor

1. Universal 's' blade

Stainless steel smooth edged processing blade is designed for cutting, kneading, whisking and emulsifying. The second smaller 's' blade is suitable for the smaller bowl.

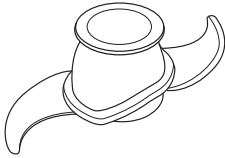

2. Variable slicing blade

The variable stainless steel slicing blade allows foods to be sliced to a variety of thicknesses, up to 7mm. This blade can not be used in the small processing bowl.

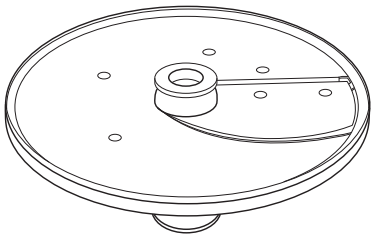

3. Julienne disc

The stainless steel julienne blade is perfect for achieving consistent julienne cut food, perfect for salad, stir fry or garnishing.

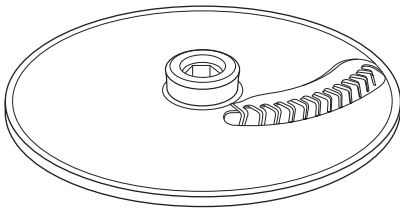

4. Reversible shredding disc - fine and coarse

Ideal control, the reversible stainless steel shredding blades allow for the choice of fine or coarse results.

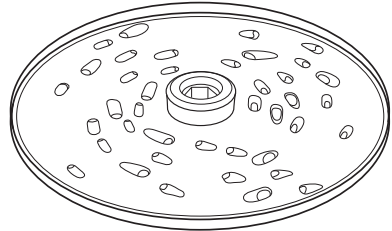

5. Reversible grating and shaving disc

Unique to processing is the shaving blade. It does lovely thin flakes, great for parmesan and sweet potato crisps. The alternate side is ideal for hard cheeses and chocolate.

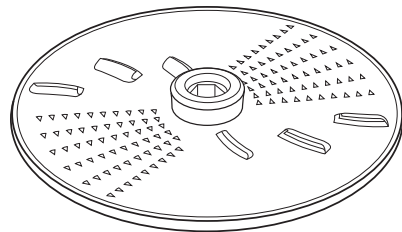

Using your Zumbo Limited Edition Food Processor

- Before using your Zumbo Limited Edition Food Processor, familiarise yourself with all parts, remove all promotional and packaging materials. Use caution when handling blades, as blades are sharp.
- Wash the processing bowl, processing cover and all attachments in warm water using a mild detergent. Dry each part thoroughly before use.
- Before you assemble the food processor, ensure that the power cord is unplugged.

1. Place the motor base facing you on a dry, level surface.
2. Place the processing bowl onto the motor base, the bowl will only sit correctly on the base when the handle is positioned to the right, see figure 1.

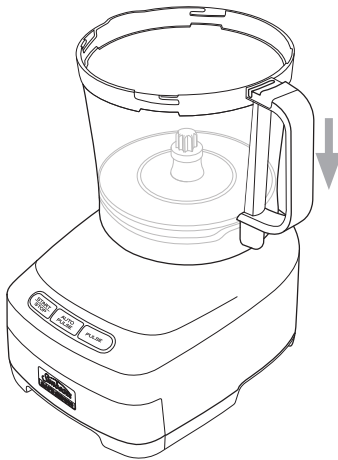

Fig 1

3. Rotate the handle clockwise to lock, as indicated by the graphics on the left side of the motorbase, see figure 2.



Fig 2

4. Position the lid onto the processing bowl. You will notice a solid grey line to the left of the holding lip on the lid, when placing the lid onto the bowl this arrow needs to align with the solid grey line on the handle of the bowl. To lock, turn the lid clockwise, as indicated by the graphics, on the top of the handle, see figure 3.

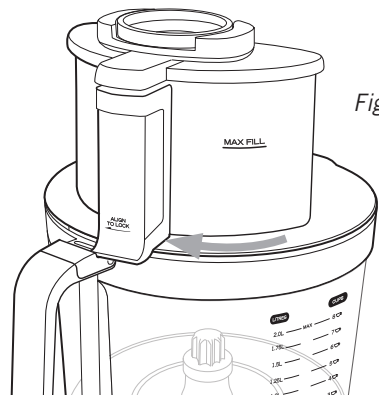

Fig 3

Using your Zumbo Limited Edition Food Processor continued

Important: If the processing bowl, processing cover and large pusher are not correctly assembled, the food processor will not operate. This is a safety feature.

Using your Food Processor

1. Plug the power cord into a 230-240V AC power outlet and turn the power 'ON'.
2. Using the START/STOP button on the control panel, press once to start processing.

The Pulse function remains on as long as the Pulse button is pressed down.

The Auto Pulse function will run for a predetermined length of time.

Further ingredients can be added whilst the appliance is running by pouring through the medium or small feed tube once the food pusher/s have been removed. Removing the large pusher will stop the motor running.

3. After you have completed processing, press the START/STOP button to stop processing.

Note: For maximum control, load the feed tube before turning on your food processor. Always use the food pusher for more evenly processed foods and never push with your fingers.

Important: The food processor is fitted with a safety thermal cut-out device and will shut off in the event of overload. If this occurs, switch the appliance off and it will automatically reset when cool.

Fitting/Using the tools on your Zumbo Limited Edition Food Processor

Note: All attachments must be firmly attached to the spindle. Always adjust the attachments until you are sure that they are correctly fitted.

Placing the spindle

1. Fit the spindle onto the drive shaft, see figure 4.

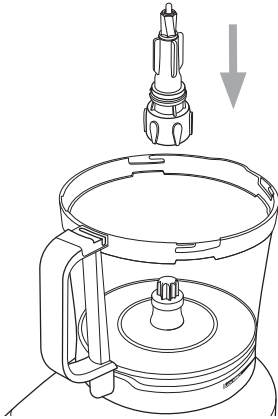

Fig 4

3. Place food into the processing bowl.
4. Fit the processing cover to the processing bowl, see figure 3 and place the food pusher in the feed chute.
5. Plug the power cord into a 230-240V AC power outlet and turn the power 'ON'.
6. Start processing using the START/STOP or Pulse buttons.
7. When processing is complete, remove the spindle and blade from the processing bowl before removing the processed food.

Universal 's' Blade

1. Fit the processing bowl and spindle as detailed previously in figures 1, 2 & 4.
2. Fit the universal 's' blade over the spindle and press firmly into place, see figure 5.

Warning: Use caution, as blades are sharp. Always handle the processing blade by its central plastic section.

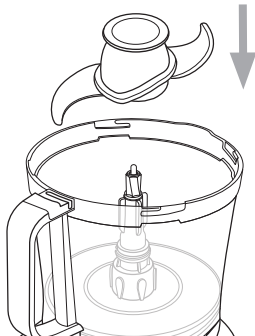

Fig 5

Fitting/Using the tools on your Zumbo Limited Edition Food Processor continued

Reversible grating/shaving, shredding and julienne discs

1. Fit the processing bowl and spindle as detailed previously, in figures 1, 2 and 4.
2. Select the 'Reversible' disc of your choice – Shredding (fine or coarse), Grating/Shaving or the dedicated Julienne disc.
3. Fit the disc over the spindle and press firmly into place, see figure 6.

Warning: Use caution as the blades are sharp.

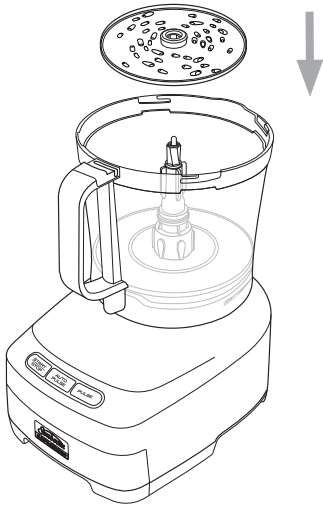

Fig 6

4. Fit the processing cover to the processing bowl as previously shown in figure 3 and place the food pusher in the feed chute.
5. Plug the power cord into a 230-240V AC power outlet and turn the power 'ON'.
6. Start processing using the START/STOP button.
7. When processing is complete, remove the disc and spindle from the processing bowl before removing the processed food.

Variable slicing blade

1. Fit the processing bowl and spindle as detailed previously in figures 1, 2 and 4.
2. Fit the slicing disc over the spindle and press firmly into place, see figure 7.



Fig 7

Warning: The variable slicing blade can be used in the large processing bowl only. Do Not use the variable slicing blade in the small bowl.

Warning: Use caution as the blades are sharp.

3. Fit the processing cover to the processing bowl as previously shown in figure 3 and place the food pusher in the feed tube.
4. Plug the power cord into 230-240V AC power outlet and turn the power 'ON'.
5. Start processing using the START/STOP button.
6. When processing is complete, remove the disc and spindle from the processing bowl before removing the processed food.

Storing your Zumbo Limited Edition Food Processor

The Zumbo Limited Edition Food Processor was designed so that all attachments can be stored within the unit itself, see figure 8.

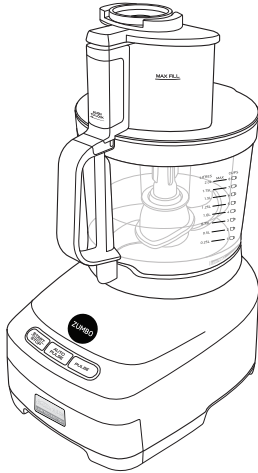

Fig 8

Storage drawer

The 'Julienne Blade', 'Reversible Shredding' disc, 'Reversible Grating and Shaving' disc are all stored in the storage drawer.

1. Slide out the storage drawer at the base of the food processor.
2. Place the small universal 's' blade at the rear of the drawer as indicated in figure 9.

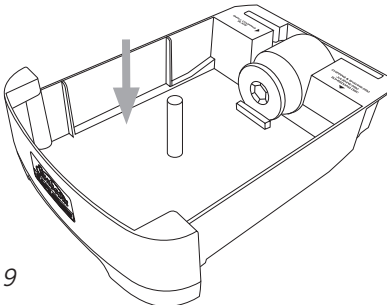

Fig 9

3. Place one of the 'Reversible discs' in storage drawer as indicated in figure 10.

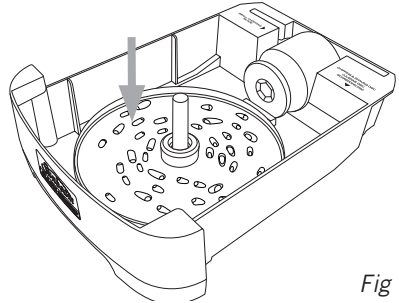

Fig 10

4. Place the 'Julienne Disc' in the storage drawer as indicated in figure 11.

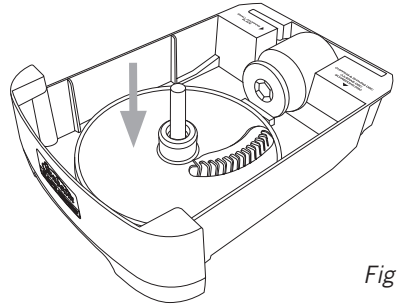

Fig 11

5. Place the remaining 'Reversible Disc' in on top of the first 'Reversible Disc' as indicated in figure 12.

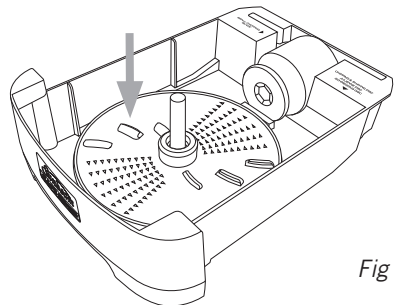

Fig 12

Storing your Zumbo Limited Edition Food Processor continued

6. Close storage drawer, see figure 13.

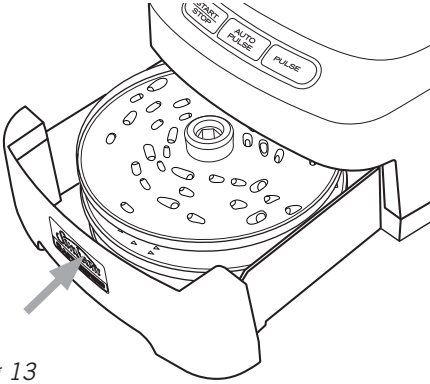

Fig 13

Processing bowl storage, see figure 14.

1. Place the processing bowl onto the base of the food processor.
2. Fit the spindle over the drive shaft.
3. Fit the large universal 's' blade over spindle.
3. Place the small bowl inside the large bowl.
4. Place the 'Variable Slicing' blade over the spindle and then fit the processing cover to the processing bowl.

Cord storage

The power cord can be stored by pushing it into the back of the motor base, see figure 15.

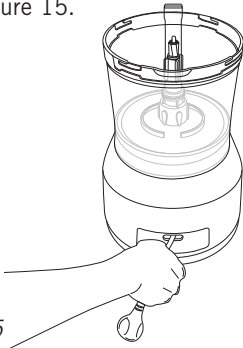

Fig 15

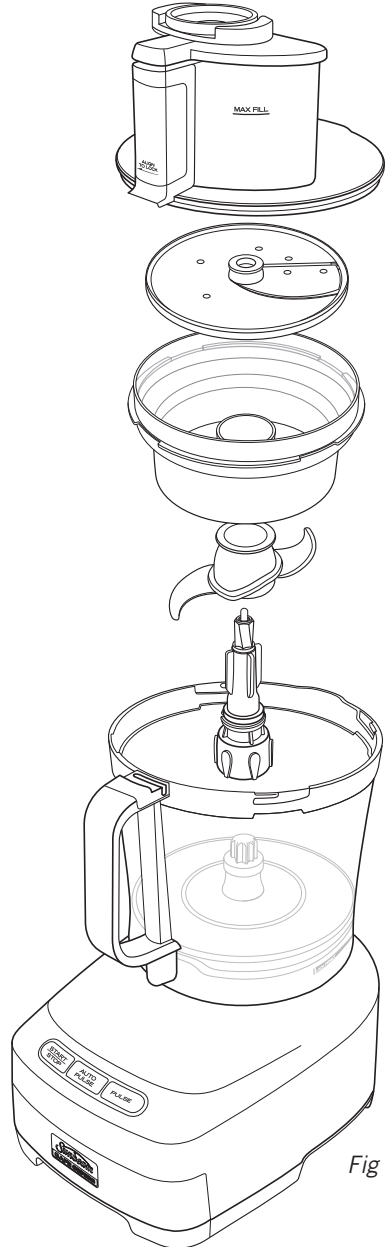

Fig 14

Handy hints for Processing

Chopping

For the best, most consistent results, you should try to process pieces of food that are approximately equal in size. When you break, cut or tear food into uniform pieces before you begin processing, the finished results will be more uniform.

More consistent processing results are achieved if the container is not overloaded.

Mincing

Pre-cut meat into cubes approximately 2cm square.

Vegetables

When processing vegetables such as onions, peel and quarter or cut large vegetables into eighths.

Mixing

The quantities that can be processed within the Processing bowl will vary with the density of the mixture.

For best results with cheese

Softer cheeses such as Cheddar or Swiss should be well chilled before processing. For best results with harder cheeses such as Parmesan or Romano, use the shaving disc, with the cheese at room temperature.

Note: When grating parmesan cheese do not apply a lot of pressure to the food pusher.

Soups

When preparing soups, always allow ingredients to cool to room temperature, before processing.

Adding Ingredients

When various recipes require dry ingredients such as flour, add them directly into the processing bowl before processing. There is no need to sift ingredients when using your food processor. Liquid ingredients may be added while the processor is operating by pouring through the feed tube in the processor cover.

Note: When processing sauces or semi-liquid ingredients, stop the food processor and scrape down the container sides with the spatula provided.

Using the Feed Tube

The most important factor for successful slicing and shredding is the way in which the food is packed into the feed tube.

When slicing, shredding, shaving or grating

Cut all ingredients to a size that fits comfortably into the feed tube. Pack the feed tube and, while holding food steady and upright with the food pusher, press down evenly until all ingredients are sliced or shredded. The more firmly you push, the thicker the slices or shreds. Do not use excessive force or you may damage the food processor.

Note: Never use fingers to push food down the feed tube. Always use the food pusher.

For best results when slicing

The feed tube should always be packed firmly to allow each piece of food to support the others. There will always be a small portion of food left unprocessed between the food pusher and the blade.

Care and cleaning

When you have finished processing, unplug the Café Series® Food Processor from the power outlet.

All accessories and processor tools can be washed in hot soapy water except for the processor body. Clean the processor body by wiping with a damp cloth.

Warning: Care must be taken when handling the metal blades as these items are extremely sharp.

Note: Always unplug the Café Series® Food Processor before cleaning.

Dishwasher Use

All plastic components deteriorate through the prolonged use of a dishwasher for cleaning.

We do not recommend to place any parts of the food processor in the dishwasher.

If using the dishwasher, place parts only on the top rack of your dishwasher. Do not place any parts in the bottom racks. This may cause plastic parts to distort due to the heating element in the dishwasher.

Notes



The Sunbeam 10 Year Motor Guarantee



Sunbeam has built its reputation on manufacturing quality electrical appliances. Our Zumbo Limited Edition Food Processor is constructed from the highest quality materials. So much so, we guarantee our Food Processor motor for ten (10) years against faulty materials or manufacture. This guarantee is just another expression of our confidence in the way we make appliances at Sunbeam. In order to be eligible for this guarantee, you must retain your receipt as proof of purchase.

Your Zumbo Limited Edition Food Processor is covered for the first year against faulty material or manufacture by the Sunbeam 12 Month Replacement Guarantee. Should you experience any difficulties with your appliance within this 12 Month period, please phone our customer service line for advice on 1300 881 861 in Australia, or 0800 786 232 in New Zealand.

The Sunbeam (10) ten year motor guarantee begins from date of purchase and extends for nine years beyond the 12 Month Replacement Guarantee. It covers only the motor, guaranteeing it against faulty materials or manufacture. It does not cover damage caused by accident, misuse or being used in a manner not in accordance with the Instruction Book. Similarly, this motor guarantee does not cover freight or any other costs incurred in making a claim.

If a fault should develop with the motor after the period covered by the 12 Month Replacement Guarantee, please call Sunbeam Customer Service on the number listed below or send a written claim to Sunbeam at the address listed below. On receipt of your claim, Sunbeam will advise you on how to obtain a replacement motor if your motor is defective. Alternatively, you can return the Zumbo Limited Edition Food Processor to any of Sunbeam's authorised service centres, together with your receipt. The service centre will examine the motor and if it is faulty or defective, the motor will be replaced free of charge.

For a complete list of Sunbeam's authorised service centres visit our website or call:

Sunbeam Corporation Ltd. Australia

www.sunbeam.com.au
1300 881 861
Units 5 & 6, 13 Lord Street
Botany NSW 2019 Australia

Sunbeam Corporation Ltd. New Zealand

www.sunbeam.co.nz
0800 786 232
26 Vestey Drive, Mt Wellington
Auckland, New Zealand

The benefits given to you by this guarantee are in addition to your other rights and remedies under any laws which relate to the appliance.

Our goods come with guarantees that cannot be excluded under the Australian Consumer Law and under the New Zealand Consumer Guarantees Act. In Australia you are entitled to a replacement or refund for a major failure and for compensation for any other reasonably foreseeable loss or damage. You are also entitled to have the goods repaired or replaced if the goods fail to be of acceptable quality and the failure does not amount to a major failure.

IMPORTANT NOTE

Sunbeam agrees to replace the motor in the event of the motor developing a fault or defect, within the four years after the 12 Month Replacement Guarantee.

As your Zumbo Limited Edition Food Processor needs to be assessed at a Sunbeam authorised service centre, it will not be accepted through retail stores.

If using the Zumbo Limited Edition Food Processor for commercial use this motor guarantee is limited to 12 months from the date of purchase.



12 Month Replacement Guarantee

In the unlikely event that this appliance develops any malfunction within 12 months of purchase (3 months commercial use) due to faulty materials or manufacture, we will replace it for you free of charge.

Should you experience any difficulties with your appliance, please phone our customer service line for advice on 1300 881 861 in Australia, or 0800 786 232 in New Zealand. Alternatively, you can send a written claim to Sunbeam at the address listed below. On receipt of your claim, Sunbeam will seek to resolve your difficulties or, if the appliance is defective, advise you on how to obtain a replacement or refund.

Your Sunbeam 12 Month Replacement Guarantee naturally does not cover misuse or negligent handling and normal wear and tear.

Similarly your 12 Month Replacement Guarantee does not cover freight or any other costs incurred in making a claim. Please retain your receipt as proof of purchase.

The benefits given to you by this guarantee are in addition to your other rights and remedies under any laws which relate to the appliance.

Our goods come with guarantees that cannot be excluded under the Australian Consumer Law and under the New Zealand Consumer Guarantees Act.

In Australia you are entitled to a replacement or refund for a major failure and for compensation for any other reasonably foreseeable loss or damage. You are also entitled to have the goods repaired or replaced if the goods fail to be of acceptable quality and the failure does not amount to a major failure.

Should your appliance require repair or service after the guarantee period, contact your nearest Sunbeam service centre.

For a complete list of Sunbeam's authorised service centres visit our website or call:

Australia

www.sunbeam.com.au

1300 881 861

Units 5 & 6, 13 Lord Street
Botany NSW 2019 Australia

New Zealand

www.sunbeam.co.nz

0800 786 232

26 Vestey Drive, Mt Wellington
Auckland, New Zealand



Need help with your appliance?

Contact our customer service team or visit our website for information and tips on getting the most from your appliance.

In Australia

Visit www.sunbeam.com.au

Or call 1300 881 861

In New Zealand

Visit www.sunbeam.co.nz

Or call 0800 786 232

Sunbeam is a registered trademark.

Made in China. Designed and engineered in Australia.
Due to minor changes in design or otherwise, the product may differ from the one shown in this leaflet.

© Copyright. Sunbeam Corporation Limited 2016.

ABN 45 000 006 771

Units 5 & 6, 13 Lord Street

Botany NSW 2019 Australia

Level 6, Building 5, Central Park

660-670 Great South Road

Greenlane, Auckland

New Zealand

Sunbeam Corporation Pty Ltd, Acn 000 006 771

LC9600Z_16EM1

GCDS-SUN46156-JC