



Home Vacuum Packaging System
Instruction Booklet

VS5000

Seal + Store



Contents

| | |
|---|-----------|
| Important Safeguards | 4 |
| Vacuum Packaging Tips | 5 |
| Features of your FoodSaver® VS5000 | |
| Vacuum Packaging System | 6 |
| Using your FoodSaver® VS5000 | |
| Vacuum Packaging System | 8 |
| Vacuum Packaging with Canisters | 10 |
| Food Preparation & Safety | 11 |
| Care and Cleaning Instructions | 12 |
| Guidelines for Vacuum Packaging | 13 |
| Preservation Guidelines | 16 |
| Vacuum Packaging Non-Food Items | 18 |
| Troubleshooting | 19 |

Important instructions – retain for future use.

تأكد من تفهم احتياطات السلامة المذكورة اعلاه

請務必理解上述的安全預防措施。

Assurez-vous que les précautions ci-dessus relatives à la sécurité sont bien comprises

Versichern Sie sich, dass die obenstehenden Sicherheitsmaßnahmen Verstanden werden

Βεβαιώστε πως οι παραπάνω προφυλάξεις ασφαλείας γίνονται κατανοητές

Pastikan bahwa tindakan-tindakan keselamatan seperti di atas dimengerti anda

Accertatevi che le suddette norme di sicurezza siano comprese a dovere

上記の注意事項をよくお読みになり、安全を御確認ください

Уверете се дека погоре споменатите мерки на претпазливост се добро разбрани

Asegúrese de que las precauciones de seguridad precedentes sean bien comprendidas

کاری یکنید کہ احتیاط‌های بالا حتماً درک بشوند

ต้องแน่ใจว่า ข้อควรระวังเรื่องความปลอดภัยข้างต้น เป็นที่เข้าใจกันดี

Yukarda belirtilen güvenlik önlemlerinin anlaşıldığından emin olunuz

Xin kiểm chắc rằng những biện pháp làm an toàn kể trên được hiểu rõ

Important Safeguards

Read the Instructions Carefully.

For Your Own Safety, Always Follow These Basic Precautions When Using the FoodSaver® Appliance:

Sunbeam is very safety conscious when designing and manufacturing consumer products, but it is essential that the product user also exercise care when using an electrical appliance. Listed below are precautions which are essential for the safe use of an electrical appliance:

- Read carefully and save all the instructions provided with an appliance.
- Always turn the power off at the power outlet before you insert or remove a plug. Remove by grasping the plug - do not pull on the cord.
- Turn the power off and remove the plug when the appliance is not in use and before cleaning.
- Do not use your appliance with an extension cord unless this cord has been checked and tested by a qualified technician or service person.
- Always use your appliance from a power outlet of the voltage (A.C. only) marked on the appliance.
- This appliance is not intended for use by persons (including children) with reduced physical, sensory or mental capabilities, or lack of experience and knowledge, unless they have been given supervision or instruction concerning use of the appliance by a person responsible for their safety.
- Children should be supervised to ensure that they do not play with the appliance.
- The temperature of accessible surfaces may be high when the appliance is operating.
- Never leave an appliance unattended while in use.
- Do not use an appliance for any purpose other than its intended use.
- Do not place an appliance on or near a hot gas flame, electric element or on a heated oven.
- Do not place on top of any other appliance.
- Do not let the power cord of an appliance hang over the edge of a table or bench top or touch any hot surface.
- Do not operate any electrical appliance with a damaged cord or after the appliance has been damaged in any manner. If damage is suspected, return the appliance to the nearest Sunbeam Appointed Service Centre for examination, repair or adjustment.
- For additional protection, Sunbeam recommend the use of a residual current device (RCD) with a tripping current not exceeding 30mA in the electrical circuit supplying power to your appliances.
- Do not immerse the appliance in water or any other liquid unless recommended.
- Appliances are not intended to be operated by means of an external timer or separate remote control system.
- This appliance is intended to be used in household and similar applications such as: staff kitchen areas in shops, offices and other working environments; farm houses; by clients in hotels, motels and other residential type environments; bed and breakfast type environments.

If you have any concerns regarding the performance and use of your appliance, please visit www.sunbeam.com.au or contact the Sunbeam Consumer Service Line.

Ensure the above safety precautions are understood.

Vacuum Packaging tips

When Vacuum Packaging:

1. Vacuum packaging is NOT a substitute for refrigeration.
2. Use only FoodSaver® bags, rolls and canisters.
3. Do not allow the Vacuum Channel to fill up with liquids. This will render the machine unusable. **To prevent it, avoid overfilling the bags and freeze liquids first.**
4. You can prevent liquids from being drawn into the appliance by placing a folded paper towel at the top of the bag, but below the seal area, before vacuum packaging. See page 9 for more details.
5. Do not attempt to create your own side seals for a FoodSaver® Bag. These bags are manufactured with special side seams which are sealed all the way to the outer edge. Creating your own side seams can actually leave air channels exposed which will cause leakage and prevent a vacuum from being formed.
6. Always make sure you leave at least 2.5 cm of extra bag material for each time you plan to reuse the bag. To avoid possible illness, **do not reuse bags after storing meats, fish or greasy foods.**
7. If you are not sure whether you have achieved a complete seal, simply seal the bag again about 1cm above the first seal.
8. Bulky items sometimes make it difficult to achieve a smooth sealing surface. Gently stretch the bag flat along the Sealing Strip before closing the lid.
9. When packaging products with sharp edges (dry spaghetti, silverware, etc.), protect the bag from punctures by wrapping the products in a cushioning material, such as paper towels, styrofoam, tissue, etc. Products can also be vacuum packaged in canisters to avoid any possibility of puncturing a bag.
10. Avoid drawing powdery or fine-grained products such as, flour, sugar and coffee grinds into the appliance. This will inhibit the vacuuming and sealing process and may clog the unit, preventing it from drawing a good vacuum. To prevent this from occurring, avoid overfilling the bags or alternatively use the FoodSaver canisters.
11. If using the FoodSaver® appliance to re-seal packets, ensure that these have been previously commercially heat sealed.

VS5000 FoodSaver® Vacuum Packaging System Seal + Store

Foam Gasket

Sealing strip

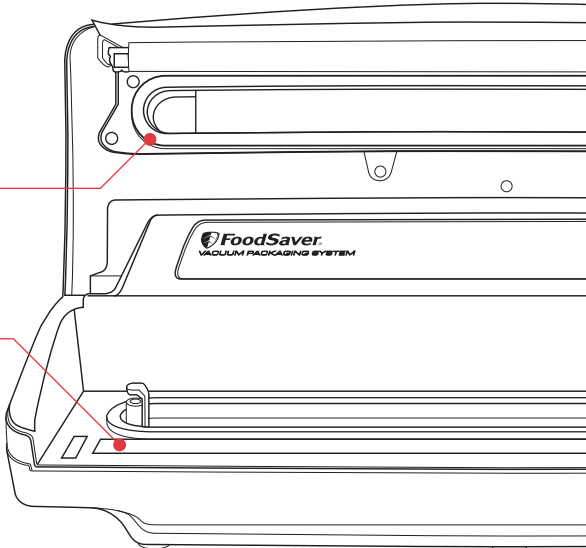

Accessory Hose Port

Attach accessory hose here and use to vacuum package with FoodSaver® Canisters.

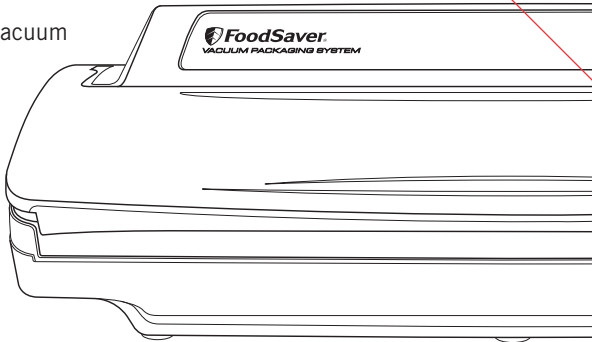

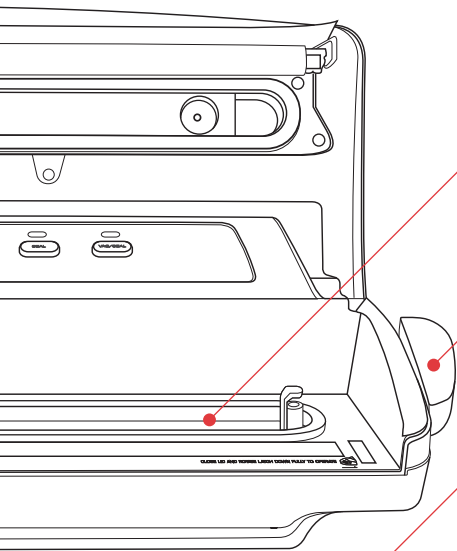

Vacuum channel

Patented removable dishwasher-safe drip tray.

Easy-lock rotating latch

Rotate the latch backwards to lock before vacuuming and sealing.

Seal Indicator Light

This light has two uses:

1. Constant light indicates sealing is in process.
2. Flashing light indicates an error.

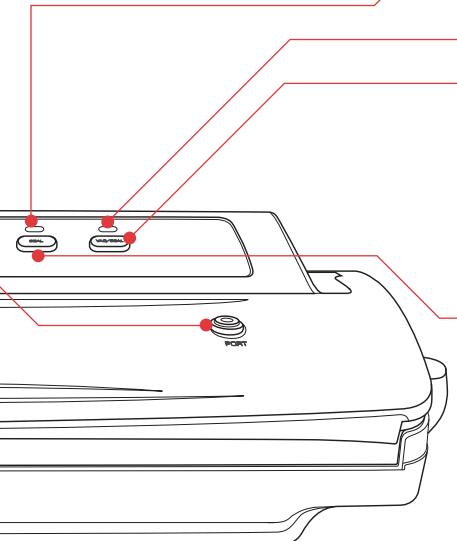

Vac/Seal Indicator Light

Vac/Seal button

This button has two uses:

1. Press to vacuum package and seal food airtight with a single touch. Shuts off automatically.
2. Press during vacuum to pause the process. Press a second time to resume.

Seal Button

This button has three uses:

1. Press to immediately stop the vacuum process and begin sealing the bag. This is helpful to prevent crushing delicate items such as bread, biscuits and pastries.
2. Press to create a seal when making bags from a FoodSaver® Roll.
3. Press to create a seal on foil based chip and cereal packets.

Using your FoodSaver® Vacuum Packaging System Seal + Store

How to make a Bag from a FoodSaver® Roll

1. Place FoodSaver® appliance on a flat, dry surface and plug the supply cord into a standard electrical outlet.
2. Pull out enough material from your roll, to hold item to be vacuum packaged
3. Cut to desired length, plus 7.5cm.
4. Open lid. The lid may be locked. To release the lid ensure the rotating latch is in the forward position.

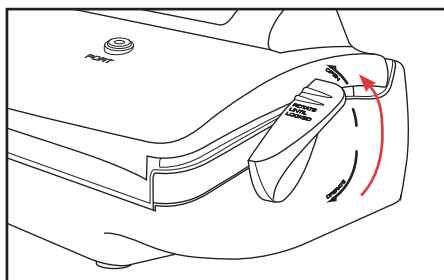

5. Place one open end of the bag material across the sealing strip and close lid. (Do not place edge of bag into vacuum channel when sealing bags)

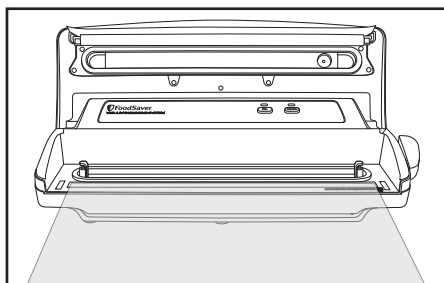

6. Lock lid by rotating the latch on the side in a backward position.
7. Press the seal button. When the seal indicator light turns off, open the lid by rotating the latch on the side in a forward position. Remove the bag.

How to Vacuum Package with FoodSaver® Bags

1. Place FoodSaver® appliance on a flat, dry surface and plug the supply cord into a standard electrical outlet.
2. Place item(s) in bag, allowing at least 7.5cm of space between bag contents and top of bag.
3. Open lid and place open end of bag into the Vacuum Channel.

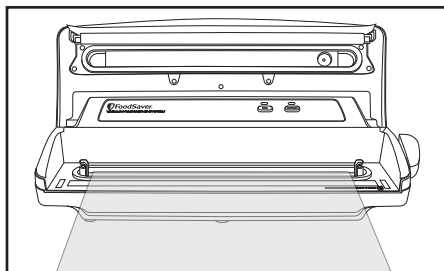

4. Close and lock the lid by rotating the latch on the side in a backward position.

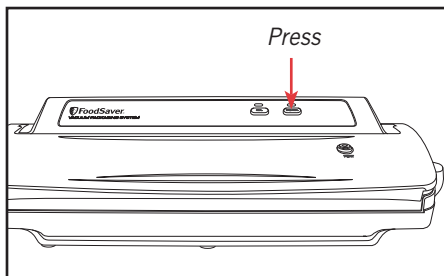

5. Press Vac/Seal button.
6. After the sealing light has gone out, rotate the latch to the forward position and remove bag.

Wait 20 seconds before vacuuming and / or sealing again.

Note: Leave the latch in the unlocked position when storing as this ensures the foam gasket is not compressed for an extended time, extending the life.

Using your FoodSaver® Seal + Store continued

Tips on sealing & vacuuming a bag

Make sure you've securely latched the FoodSaver® appliance lid. When making a bag from a roll, place bag material on the sealing strip, close and latch the lid.

Prevent moisture or liquid from being pulled into the Vacuum Channel or trapped in the seal.

Pre-freeze moist food such as raw meat for 1-2 hours before vacuum packaging, or place a folded paper towel between food and end of bag to absorb excess liquids. Just be sure to leave at least 2.5cm between food and end of bag so that bag seals properly with paper towel inside.

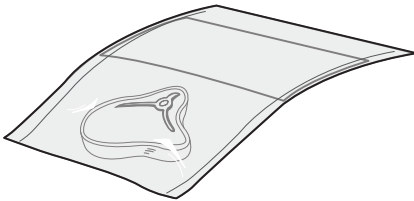

Make sure you give FoodSaver® appliance time to cool down. Wait at least 20 seconds between seals. Under very heavy usage, appliance will not operate to prevent overheating. If it does, wait 20 minutes to allow appliance to cool off.

Vacuum packaging in bulk

To package a large number of bags at one time, it is recommended to:

- create bag
- place foods in bag
- vacuum & seal
- repeat

Following this process will prevent the appliance from overheating. Do not for example: create 10 bags, then vacuum & seal 10 bags as this can overheat the heating element.

Make sure you've securely latched the FoodSaver® appliance lid. When vacuuming and sealing a bag or canister, ensure the locking latch is rotated in the backward position.

Check for wrinkles in the bag along the Sealing Strip. Wrinkles in seal may cause leakage and allow air to come back into bag. Check for wrinkles in bag along Sealing Strip before closing lid and vacuum packaging. If you find wrinkles after sealing bag, simply cut bag open and vacuum seal again.

If the motor runs for more than 30 seconds without stopping, consider the following:

- adjust the bag and try again.
- if you are making an initial seal on a piece of bag material with two open ends, make sure the bag is placed on the sealing strip.
- if you are vacuum packaging with a bag, make sure the open end is placed down inside the vacuum channel.
- ensure the accessory hose is not attached.

Vacuum Packaging with Canisters

1. Always leave 2.5cm of space between contents and rim.
2. Wipe rim of canister to ensure it's clean and dry.
3. Place the appliance on a flat, dry surface and plug the supply cord into a standard electrical outlet.
4. **Canisters:** place the item(s) to be vacuum packaged inside the canister. Place the lid on top of the canister.
5. Insert one end of the Accessory Hose into the Accessory Port on the appliance. Insert the other end of the hose into the canister. Twist tab on Accessory Hose while inserting to ensure a tight fit. See figure 1 & 2.
6. To begin the vacuum process, lock lid by rotating the latch on the side in a backward position.
7. Press the Vac/Seal button.

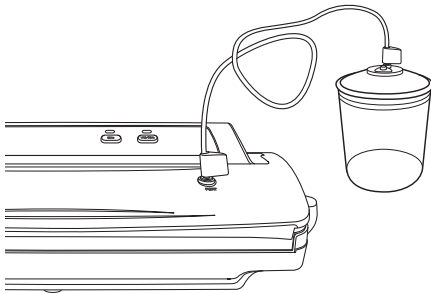

Figure 1

8. When the motor and indicator light turn off, vacuum process is complete. Note that the appliance will still go through sealing cycle even when vacuuming an accessory. You will hear the motor shut off and then the sealing cycle will begin
9. To remove accessory hose, gently twist and remove hose from the appliance and canister. Unlock side latches.

How to Open the FoodSaver® Canister

To open, press and hold down the grey rubber button in the centre of the lid. This will release the vacuum – a hissing sound can be heard as the air rushes in.



Figure 2

IMPORTANT: Remember to remove the Accessory Hose from the Accessory Port on the appliance before you vacuum package in FoodSaver® Bags.

Food Preparation & Safety tips

Guidelines for Vacuum Packaging Food

Vacuum packaging is not a substitute for canning nor can it reverse deteriorating quality; it can only slow down changes in quality. It is impossible to predict how long a specific food will have top-quality flavour, appearance and texture, because it depends on the age and condition of the food on the day it was vacuum packaged. Foods that are extremely fresh will last longer than foods that are already deteriorating.

Vacuum packaging extends the life of foods by removing nearly all the air in a sealed container, thereby reducing oxidation which affects nutritional value, flavour and overall quality. However, most foods contain enough water to support micro-organisms which can grow with or without air. While micro-organisms are present everywhere, only certain ones cause problems, and only under certain conditions:

- **Mould:** Easy to identify because of its characteristic fuzz. Moulds are virtually eliminated by vacuum packaging because they cannot grow in a low oxygen environment.
- **Yeast:** Results in fermentation, which can frequently be identified by smell or taste. Yeast requires water, sugar and a moderate temperature to grow, and can grow with or without air. Refrigeration slows the growth of yeast, and freezing stops it completely.

- **Bacteria:** Frequently results in discolouration, soft or slimy texture, and/or an unpleasant odour. 'Clostridium botulinum' (the organism that causes Botulism) can grow without air under the right conditions, cannot be detected by smell or taste, and although extremely rare, can be very dangerous.

Thawing and Heating Vacuum Packaged Foods

Always thaw foods in either the refrigerator or microwave – do not leave “perishable” foods at room temperature to thaw.

To microwave in a FoodSaver® Bag, cut a corner of the bag and place on a microwave-safe dish.

The combination of vacuum packaging and freezing will extend food freshness and reduce the growth of bacteria in perishable foods.

Maintaining low temperatures is a critical factor in preserving foods safely. Growth of micro-organisms is significantly reduced at temperatures of 4°C or below. Freezing at -17°C does not kill micro-organisms, but it stops them from growing. For long term storage, always freeze “perishable” foods that have been vacuum packaged.

NOTE: Vacuum packaging is NOT a substitute for refrigeration or freezing. Any “perishable” foods that require refrigeration prior to vacuum packaging still must be refrigerated or frozen after vacuum packaging.

Care and Cleaning Instructions

The FoodSaver® Appliance

1. Always unplug the appliance before cleaning.
2. Clean using a mild dishwashing soap and a warm, damp cloth. Do not immerse the appliance in water. Dry thoroughly before using.
3. Do not use abrasive products or materials to clean any of the appliance components.

Drip Tray

Remove from appliance for easy clean.
Clean drip tray in warm soapy water.

FoodSaver® Bags

IMPORTANT: Do not reuse bags after storing meats, fish or greasy foods.

1. Wash bags in warm water using a mild dishwashing soap.
2. Bags can be washed in the dishwasher by carefully turning the bags inside out and spreading them over the top rack of the dishwasher so that all surfaces are exposed to the washing water.
3. Allow bags to dry thoroughly before reusing. To avoid possible illness, do not reuse bags after storing raw meats, fish or greasy foods. **Do not reuse bags that have been microwaved or simmered.**

FoodSaver® Accessories

1. All FoodSaver® accessories should be washed in warm water using a mild dishwashing soap. Dry thoroughly before using.
2. The FoodSaver® Canister base (clear) can be cleaned in the dishwasher but only in the top shelf. Items washed in bottom shelves can distort due to the heat from the dishwasher element. FoodSaver® Canister lids are NOT dishwasher safe

IMPORTANT: All plastic components deteriorate through the prolonged use of a dishwasher for cleaning. Hand washing of plastic components in warm soapy water is always recommended.

Guidelines for Vacuum Packaging

Vacuum Packaging and Food Safety

The vacuum packaging process extends the life of foods by removing most of the air from the sealed container. This reduces oxidation, which affects nutritional value, flavour and overall quality.

Removing air can also inhibit growth of micro organisms, which can cause problems under certain conditions such as mould, yeast and bacteria.

IMPORTANT: Vacuum packaging is NOT a substitute for refrigeration or freezing. Beef

Any perishable foods that require refrigeration must still be refrigerated or frozen after vacuum packaging.

Thawing and Reheating Vacuum Packaged Foods

Always thaw foods in either refrigerator or microwave — do not thaw perishable foods at room temperature.

Reheating in a microwave

To reheat foods in a microwave in a FoodSaver® Bag, always cut corner of the bag before placing it on a microwave-safe dish. However, to avoid hot spots, do not reheat bone-in meat or greasy foods in microwave within a FoodSaver® Bag.

Reheating in water

You can also reheat foods in FoodSaver® Bags by placing them in water at a low simmer below 75°C.

Vacuum Packaging Meat and Fish:

For best results, pre-freeze meat and fish for 1-2 hours before vacuum packaging in a FoodSaver® Bag. This helps retain the juice and shape, and guarantees a better seal.

If it's not possible to pre-freeze, place a folded paper towel in the bag, between meat/ fish and top of bag, below seal area. Leave paper towel in bag to absorb excess moisture and juices during vacuum packaging process.

Note: Beef may appear darker after vacuum packaging due to the removal of oxygen. This is not an indication of spoilage.

Vacuum Packaging Hard Cheeses:

To keep cheese fresh, vacuum package it after each use. To continue using the same bag, when initially vacuum packaging the cheese, ensure the FoodSaver® Bag is extra long. Allow one inch of bag material for each time you plan to open and reseal the bag in addition to the 7cm space you normally leave between contents and seal. Simply cut sealed edge and remove cheese prior to use. When you're ready to repack the cheese, just drop it in bag and reseal.

IMPORTANT: Due to the risk of anaerobic bacteria, Soft cheeses should never be vacuum packaged.

Guidelines for Vacuum Packaging continued

Vacuum Packaging Vegetables:

It is recommended that vegetables are blanched before vacuum packaging.

This process stops the enzyme action that could lead to loss of flavour, colour and texture.

To blanch vegetables, place them in boiling water or in the microwave until they are cooked, but still crisp.

Approximate blanching times:

- 1 to 2 minutes for leafy greens and peas
- 3 to 4 minutes for snap peas, sliced zucchini or broccoli
- 5 minutes for carrots
- 7 to 11 minutes for corn on the cob.

After blanching, immerse vegetables in cold water to stop the cooking process.

Dry vegetables on a towel before vacuum packaging.

For best results, it is recommended to pre-freeze vegetables for 1-2 hours or until solidly frozen. To freeze vegetables in individual servings, first place on a baking sheet and spread them out so they are not touching. This prevents them from freezing together in a block. Once they are frozen, remove from baking sheet and vacuum package.

After they have been vacuum packaged, return them to the freezer.

Note: All vegetables (including broccoli, Brussels sprouts, cabbage, cauliflower, kale, turnips) naturally emit gases during storage. Therefore, after blanching, they must be stored in freezer only.

IMPORTANT: Due to the risk of anaerobic bacteria, Fresh mushrooms, onions, & garlic should never be vacuum packaged.

Vacuum Packaging Leafy Vegetables:

For best results, use a canister to store leafy vegetables. First wash the vegetables, and then dry with a towel or salad spinner. After they are dried, put them in a canister and vacuum package. Store in refrigerator.

Vacuum Packaging Fruits:

When freezing soft fruits or berries, it is best to pre-freeze them for 1-2 hours or until solidly frozen. To freeze fruit in individual servings, first place on a baking sheet and spread them out so they are not touching. This prevents them from freezing together in a block.

Once they are frozen, remove from baking sheet and vacuum package fruit. After they have been vacuum packaged, return them to the freezer.

You can vacuum package portions for baking, or in your favourite combinations for easy fruit salad all year round.

If storing in the refrigerator, we recommend using a FoodSaver® Canister.

Vacuum Packaging Baked Goods:

To vacuum package soft or airy baked goods, we recommend using a FoodSaver® Canister so they will hold their shape. If using a bag, pre-freeze for 1-2 hours or until solidly frozen. To save time, make cookie dough, pie shells, whole pies, or mix dry ingredients in advance and vacuum package for later use.

Guidelines for Vacuum Packaging continued

Vacuum Packaging Coffee and Powdery Foods:

To prevent food particles from being drawn into vacuum pump, place a coffee filter or paper towel inside the bag, above the coffee and below the top of the bag, before vacuum packaging.

You can also place the food in its original bag inside a FoodSaver® Bag.

Vacuum Packaging Liquids:

Before you vacuum package liquids such as soup stock, pre-freeze in a casserole dish, loaf pan or ice cube tray until solid. Remove frozen liquid from pan and vacuum package in a FoodSaver® Bag. You can stack these “frozen bricks” in your freezer. When you’re ready to use, just cut corner of bag and place in a dish in microwave or drop into water at a low simmer, below 75°C.

Vacuum Packaging Snack Foods:

Your snack foods will maintain their freshness longer when you vacuum package them. For best results, use a FoodSaver® Canister for crushable items like crackers.

Vacuum Packaging Non-Food Items

The FoodSaver® vacuum packaging system also protects non-food items from oxidation, corrosion and moisture. Simply follow the directions to vacuum package items using FoodSaver® Bags & Canisters.

To vacuum package silver, wrap forks in soft cushioning material, such as a paper towel, to avoid puncturing bag.

Your FoodSaver® Bags are ideal for outdoor excursions. For camping and hiking, keep your matches, maps and food dry and compact.

To have fresh water for drinking, simply fill a FoodSaver® Bag with ice, seal it and when needed, let the ice pack melt.

If you’re going sailing or boating, vacuum package your food, film and a dry change of clothes. Just remember to bring scissors or a knife to open the bag.

To keep emergency kits safe and dry, vacuum package flares, batteries, flashlights, matches, candles and other necessities. Your emergency items will stay dry and organized in your home, car or boat.

Natural Gases in Foods

The release of natural gases or fermentation from foods, (such as fresh fruits and vegetables) can add air back into a vacuum packaged bag. To prevent this occurring, vegetables can be blanched prior to vacuum packing. See page 14 for more details. Pre-freezing meats prior to vacuum packaging can prevent natural gases being released.

Preservation Guidelines

| Foods | Where to Store | Recommended FoodSaver® Container | Storage Life with FoodSaver® Vacuum Packaging System | Normal Storage Life |
|--|----------------|----------------------------------|--|---------------------|
| Meat | | | | |
| Beef, Pork, Lamb | Freezer | FoodSaver® Bag | 2-3 years | 6 months |
| Ground Meat | Freezer | FoodSaver® Bag | 1 year | 4 months |
| Poultry | Freezer | FoodSaver® Bag | 2-3 years | 6 months |
| Fish | Freezer | FoodSaver® Bag | 2 years | 6 months |
| Hard Cheeses | | | | |
| Cheddar, Swiss | Refrigerator | FoodSaver® Bag, Canister | 4-8 months | 1-2 weeks |
| Parmesan | Refrigerator | FoodSaver® Bag, Canister | 4-8 months | 1-2 weeks |
| Vegetables (Vegetables, excluding leafy types, must be blanched before vacuum sealing.) | | | | |
| Asparagus | Freezer | FoodSaver® Bag | 2-3 years | 8 months |
| Broccoli, Cauliflower | Freezer | FoodSaver® Bag | 2-3 years | 8 months |
| Cabbage, Brussels Sprouts | Freezer | FoodSaver® Bag | 2-3 years | 8 months |
| Corn (cob or kernel) | Freezer | FoodSaver® Bag | 2-3 years | 8 months |
| Green Beans | Freezer | FoodSaver® Bag | 2-3 years | 8 months |
| Lettuce, Spinach | Refrigerator | FoodSaver® Canister | 2 weeks | 3-6 days |
| Snow Peas, Snap Peas | Freezer | FoodSaver® Bag | 2-3 years | 8 months |
| Fruits | | | | |
| Apricots, Plums | Freezer | FoodSaver® Bag | 1-3 years | 6-12 months |
| Peaches, Nectarines | Freezer | FoodSaver® Bag | 1-3 years | 6-12 months |
| Softer Berries | | | | |
| Raspberries, Blackberries | Refrigerator | FoodSaver® Canister | 1 week | 1-3 days |
| Strawberries | Refrigerator | FoodSaver® Canister | 1 week | 1-3 days |
| Harder Berries | | | | |
| Blueberries | Refrigerator | FoodSaver® Canister | 2 weeks | 3-6 days |
| Cranberries | Refrigerator | FoodSaver® Canister | 2 weeks | 3-6 days |

Preservation Guidelines continued

| Foods | Where to Store | Recommended FoodSaver® Container | Storage Life with FoodSaver® Vacuum Packaging System | Normal Storage Life |
|-------------------------|-----------------------|---|---|----------------------------|
| Baked Goods | | | | |
| Bagels, Bread, Pastries | Freezer | FoodSaver® Bag | 1-3 years | 6-12 months |
| Nuts | | | | |
| Almonds, Peanuts | Pantry | FoodSaver® Bag, Canister | 2 years | 6 months |
| Sunflower Seeds | Pantry | FoodSaver® Bag, Canister | 2 years | 6 months |
| Coffee | | | | |
| Coffee Beans | Freezer | FoodSaver® Bag | 2-3 years | 6 months |
| Coffee Beans | Pantry | FoodSaver® Bag, Canister | 1 year | 3 months |
| Ground Coffee | Freezer | FoodSaver® Bag | 2 years | 6 months |
| Ground Coffee | Pantry | FoodSaver® Bag, Canister | 5-6 months | |
| Prepared Liquids | | | | |
| Sauces, Soups, Stews | Freezer | FoodSaver® Bag | 1-2 years | 3-6 months |
| Bottled Liquids | | | | |
| Wine | Refrigerator | FoodSaver® Bottle Stopper | 2-4 months | 1-3 weeks |
| Oils | Pantry | FoodSaver® Bottle Stopper | 1-1½ years | 5-6 months |
| Dry Foods | | | | |
| Beans, Grains | Pantry | FoodSaver® Bag, Canister | 1-2 years | 6 months |
| Pasta, Rice | Pantry | FoodSaver® Bag, Canister | 1-2 years | 6 months |
| Powdery Foods | | | | |
| Dry Milk | Pantry | FoodSaver® Bag, Canister | 1-2 years | 6 months |
| Dried Coconut | Pantry | FoodSaver® Bag, Canister | 1-2 years | 6 months |
| Flour | Pantry | FoodSaver® Bag, Canister | 1-2 years | 6 months |
| Sugar, Brown Sugar | Pantry | FoodSaver® Bag, Canister | 1-2 years | 6 months |
| Snack Foods | | | | |
| Chips | Pantry | FoodSaver® Canister | 3-6 weeks | 1-2 weeks |
| Cookies, Crackers | Pantry | FoodSaver® Canister | 3-6 weeks | 1-2 weeks |

Vacuum Packaging Non-Food Items

Your FoodSaver® appliance also protects non-food items from oxidation, corrosion and moisture.

Just follow the directions for vacuum packaging using the FoodSaver® Bags, Canisters and Accessories.

- Camping and hiking gear stays dry and compact. Vacuum packaging your clothes and equipment will help save space in your bag. Vacuum package matches, maps and anything you want to stay dry.
- For picnics, fill a FoodSaver® Bag with ice and seal. When it melts, you'll have fresh water for drinking or you can put it back in the freezer as a reusable ice pack.
- For painting, vacuum package your wet paint brush between coats rather than washing out. Particularly useful for oil based paints that require mineral turpentine to clean up.
- Vacuum package your food and equipment for a boating or sailing outing. Food will stay dry in the cooler/esky. Batteries and film won't get damaged by water, and you'll appreciate having a dry change of clothes.
- Vacuum package first aid kits and emergency kits for your house, your boat and your car. Items will all be in one package and will stay dry and without dirt and mold. Include flares, batteries, flashlight, candles and matches.
- To vacuum package silver, wrap fork prongs in soft cushioning material, such as a paper towel, to avoid puncturing bag.

Troubleshooting

Nothing happens when the on button is pressed:

- Check to see that the appliance is plugged in. Test electrical outlet by plugging in another appliance.
- The appliance will shut off automatically if overheated. Allow to cool down for 20 minutes and try again.
- Check supply cord and plug for damage. If damaged, do not use the appliance.

Air is not removed from the bag:

- To seal properly, open end of bag should be resting entirely inside Vacuum Channel area.
- Check sealing strip and gasket beneath the lid for debris. Wipe off and then smooth back into place.
- After extended use, the gasket may need to be replaced. Please contact Sunbeam Customer.
- Bag may have a leak. To test, seal the bag with some air in it, submerge in water, and apply pressure. Bubbles indicate a leak. Reseal or use another bag.
- Open bag and dry/wipe at top end of bag. Ensure no food particles are in/around top of bag.

Air was removed from the bag, but has come back into the bag:

- Leaks along the seal can be caused by wrinkles, crumbs, grease or liquids. Reopen bag, wipe the top inside of the bag and smooth it out along the sealing strip before resealing.
- The release of natural gases or fermentation from foods, (such as fresh fruits and vegetables) may have occurred. Most vegetables require blanching prior to vacuum packing. See page 14 for more details. Open bag, if you think food has begun to spoil, discard food. Lack of refrigeration or fluctuating temperatures in the Refrigerator can cause food to spoil.

- Check the bag for a puncture or hole, which may have released the vacuum. Cushion sharp edges in the contents of the bag with paper towels.

The Bag Melts:

- Should sealing strip overheat and melt the bag, it may be necessary to lift the lid and allow sealing strip to cool for a few minutes.
- Built-in safety shut-off may shut the appliance off if it becomes overheated. Allow the unit to cool down for 20 minutes and try again.

The FoodSaver® Canister will not vacuum:

- Make sure the rubber gasket on the canister lid is free from food materials, crumbs, coffee grinds, etc.
- Make sure the rim of the canister does not have any cracks or scratches. Any gaps can prevent a vacuum from forming.
- Make sure you aren't filling the canister too full prior to vacuum packaging. Always leave at least 2.5cm between the contents and the lid.

NOTE: For all accessories, make sure the Accessory Hose is completely inserted into appliance and lid of accessory. Twist grey tab on Accessory Hose while inserting to ensure a tight fit.

Built-in safety shut-off and overheating

Under heavy usage the appliance can stop, to prevent overheating. The overheating is caused by a protection feature in the appliance that prevents the heating element getting too hot. If the heating element gets too hot, it will melt and seal the bag before vacuuming therefore not reaching the desired vacuum packaged result.

If this does occur, wait 20 minutes to allow appliance to cool off.

Notes

Notes

Notes

12 Month Warranty

This Sunbeam product is covered by a 12 month replacement or repair warranty, which is in addition to your rights under the Australian Consumer Law (if your product was purchased in Australia) or New Zealand Consumer Guarantees Act (if your product was purchased in New Zealand).

Should you experience any difficulties with your product during the warranty period, please contact our customer service line for advice on 1300 881 861 in Australia, or 0800 786 232 in New Zealand.

Alternatively, you can send a written claim to Sunbeam to:

Australia

Units 5 & 6, 13 Lord Street
Botany NSW 2019 Australia

New Zealand

Level 6, Building 5, Central Park,
660-670 Great South Road,
Greenlane, Auckland

Upon receipt of your claim, Sunbeam will seek to resolve your difficulties or, if the product is defective, advise you on how to obtain a replacement or refund.

To assist us in managing warranty claims, we recommend you register your product as soon as practicable after purchase by creating a MySunbeam account on our website and send a copy of your original receipt to Sunbeam.

In order to make a claim under our warranty, you must have the original proof of purchase documentation for the product and present it when requested.

Should your product develop any defect within 12 months of purchase because of faulty materials or workmanship, we will replace or repair it, at our discretion, free of charge. A product presented for repair may be replaced by a refurbished product of the same type rather than being repaired. Refurbished parts may be used to repair the product.

Our replacement or repair warranty only applies where a defect arises as a result of faulty material or workmanship during the warranty period. Your warranty does not cover misuse or negligent handling (including damage caused by failing to use the product in accordance with this instruction booklet), accidental damage, or normal wear and tear.

Your warranty does not:

- cover freight or any other costs incurred in making a claim, consumable items, accessories that by their nature and limited lifespan require periodic renewal (such as filters and seals) or any consequential loss or damage; or
- cover damage caused by:
 - power surges, power dips, voltage supply problems, or use of the product on incorrect voltage;
 - servicing or modification of the product other than by Sunbeam or an authorised Sunbeam service centre;
 - use of the product with other accessories, attachments, product supplies, parts or devices that do not conform to Sunbeam specifications; or
 - exposure of the product to abnormally corrosive conditions; or
- extend beyond 3 months if the product is used in commercial, industrial, educational or rental applications.

The benefits given to you by our warranty are in addition to other rights and remedies under law in relation to the product.

In Australia our goods come with guarantees that cannot be excluded under the Australian Consumer Law. You are entitled to a replacement or refund for a major failure and for compensation for any other foreseeable loss or damage. You are also entitled to have the goods repaired or replaced if the goods fail to be of acceptable quality and the failure does not amount to a major failure.

Our goods also come with guarantees that cannot be excluded under the New Zealand Consumer Guarantees Act.

If your warranty claim is not accepted, we will inform you and if requested to do so by you, repair the product provided you pay the usual charges for such repair. You will also be responsible for all freight and other costs.

Should your product require repair or service after the warranty period, contact your nearest Sunbeam service centre. For a complete list of Sunbeam's service centres, visit our website or call our customer service line for advice on 1300 881 861 in Australia, or 0800 786 232 in New Zealand.

Need help with your appliance?

Contact our customer service team or visit our website for information and tips on getting the most from your appliance.

In Australia

Visit www.sunbeam.com.au

Or call 1300 881 861

In New Zealand

Visit www.sunbeam.co.nz

Or call 0800 786 232

Distributed by:

Sunbeam Corporation Limited
ABN 45 000 006 771

Sunbeam Corporation is a division of GUD Holdings Ltd.

 is a registered trademark.

www.sunbeam.com.au
Units 5 & 6, 13 Lord St Botany
NSW 2019 Australia

Level 6, Building 5, Central Park
660-670 Great South Road
Greenlane, Auckland
New Zealand

© 2014 Sunbeam Products Inc. doing business as Jarden
Consumer Solutions. All rights reserved.

FoodSaver® is a registered trademark of Sunbeam Products,
Inc. Some images and text are copywrited.

2928-A-IB
10/14