

ASSEMBLY INSTRUCTIONS

AVOCA DOUBLE BED

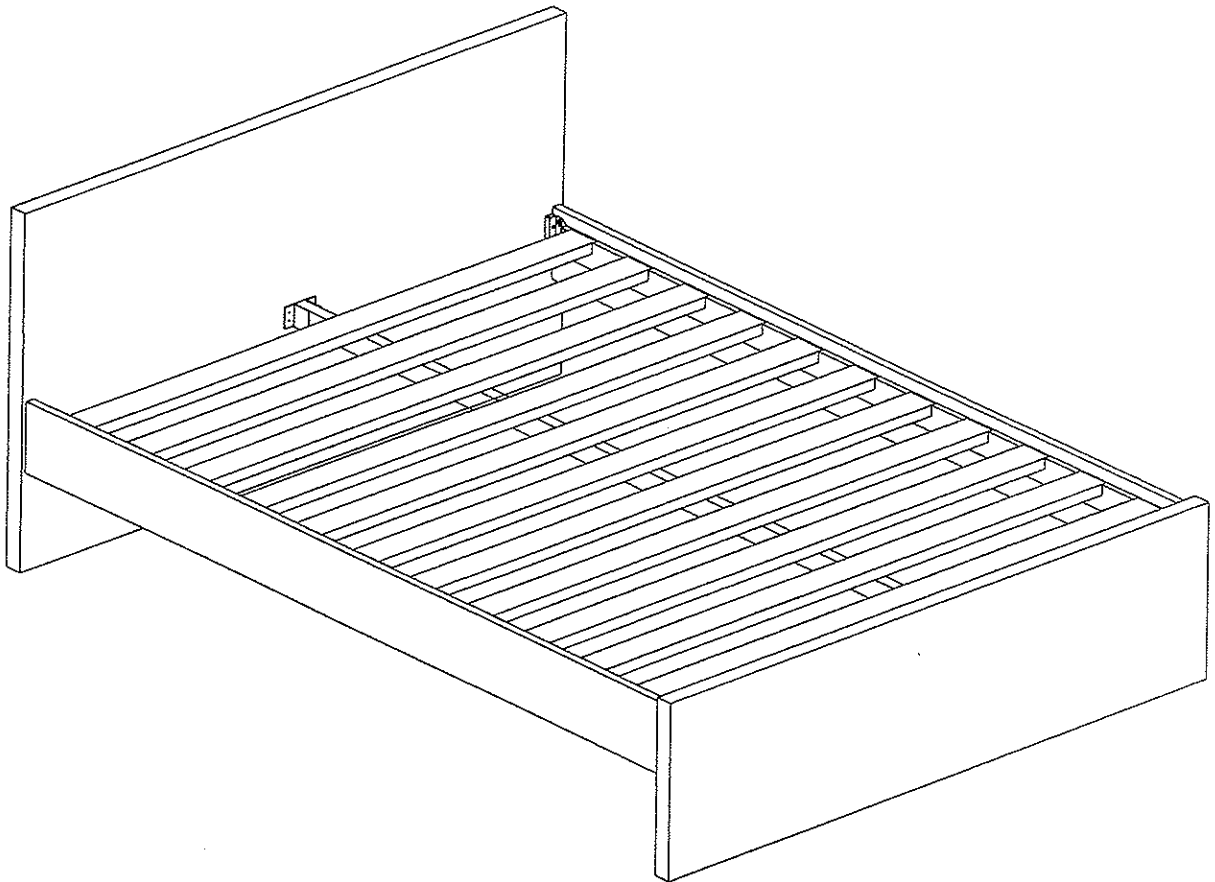

STOP!

Before you start...

1

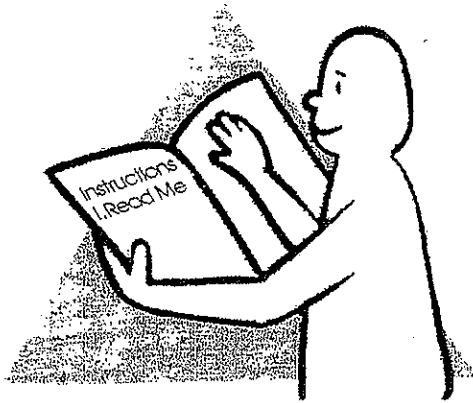

Read instructions carefully.

2

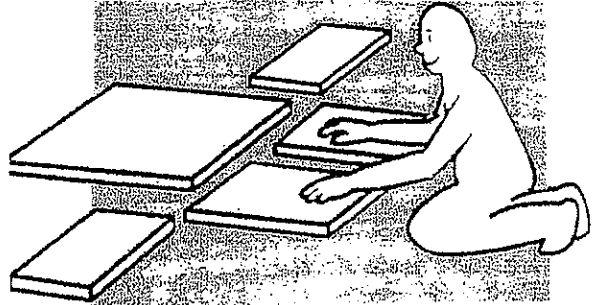

Lay out all of the components on a soft surface as if you were preparing to do a jigsaw puzzle.

3

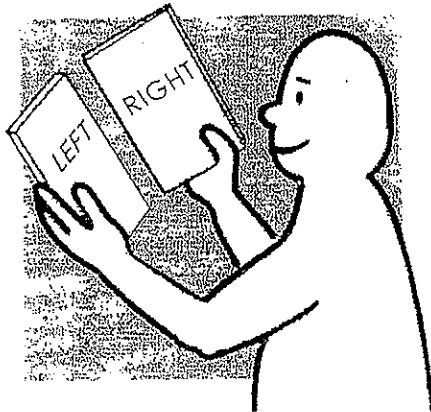

Carefully identify each component, especially those that are similar. The most common mistake is getting things back to front.

4

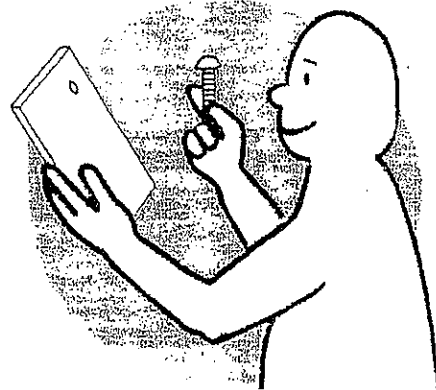

Separate and identify each component from the hardware pack and rest each one in its proper location before fastening.

5

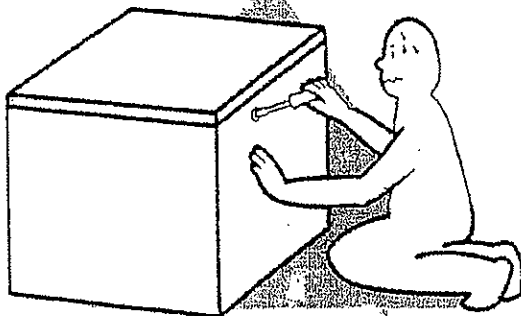

DO NOT over-tighten screws

6

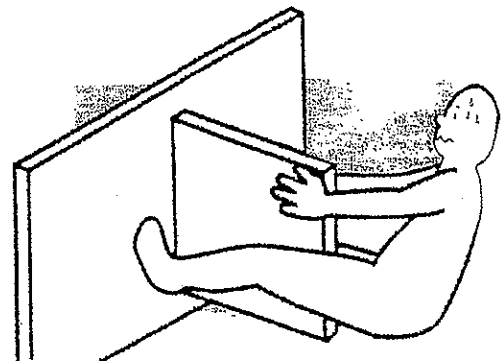

DO NOT set glue until you are certain that the parts belong together.

TOOLS NEEDED

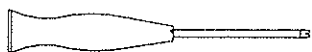



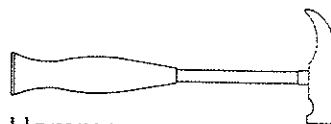



Phillips Screwdriver

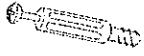
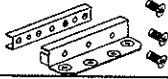
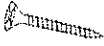

Hammer

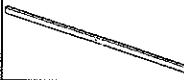
HARDWARE CHECK

HARDWARE	CODE	QTY PER UNIT	DESCRIPTION & APPLICATION	HARDWARE	CODE	QTY PER UNIT	DESCRIPTION & APPLICATION
	H1	8	Cam (mm)		H2	8	Cam Bolt
	H73	4	Bed Bracket		H71	16	16mm Screw
	H72	1	Alan Key		H4	22	30 mm Screw
	H11	4	Furniture Glide		H113	24	25mm Screw
	H111	1	Support Tube		H112	2	Support Bracket

LAYOUT OF PARTS

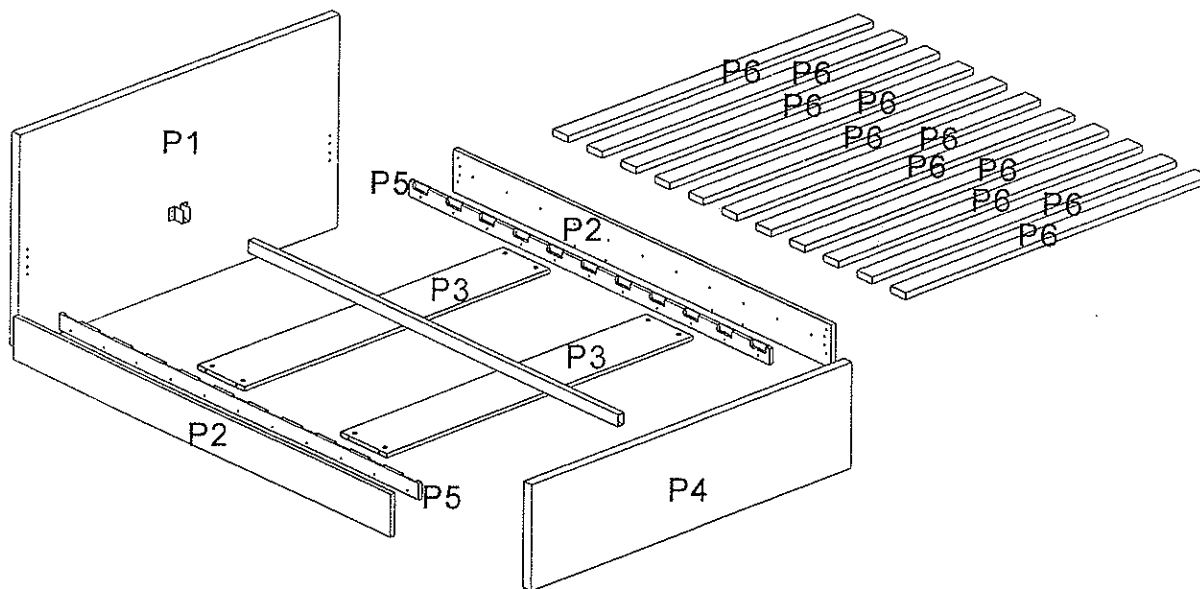

STEP 1.

WHAT YOU NEED	
	H1X8

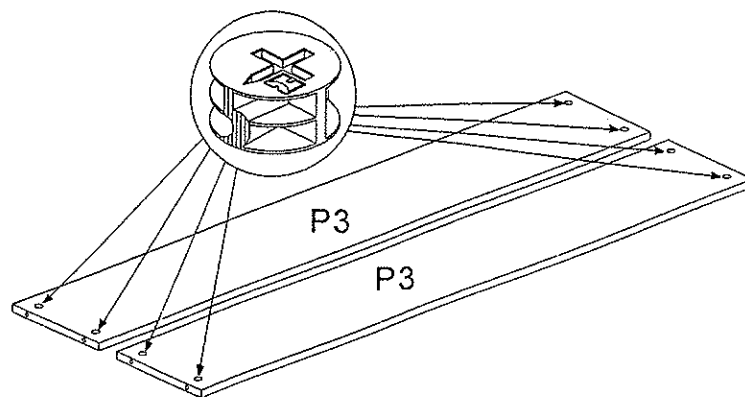

STEP 2.

WHAT YOU NEED

	H2×8
---	------

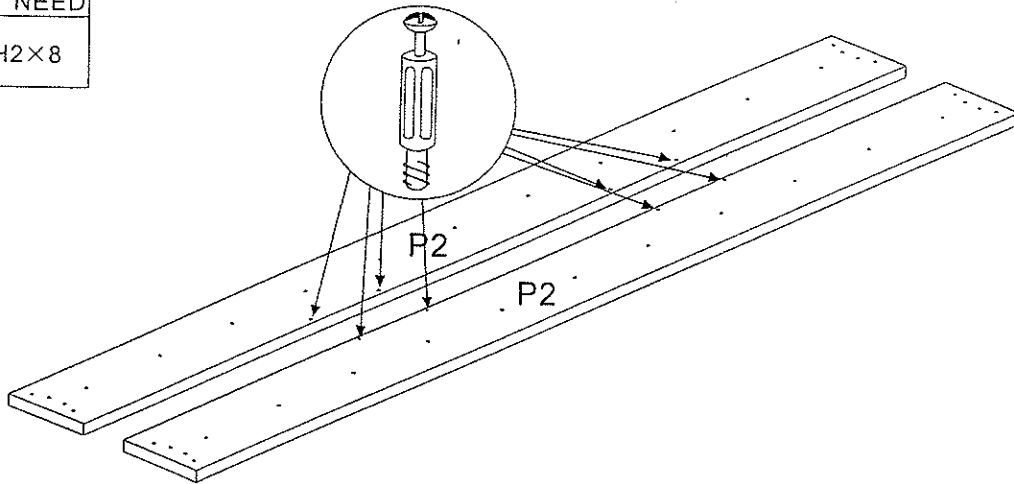

STEP 3.



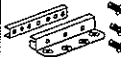
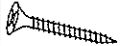

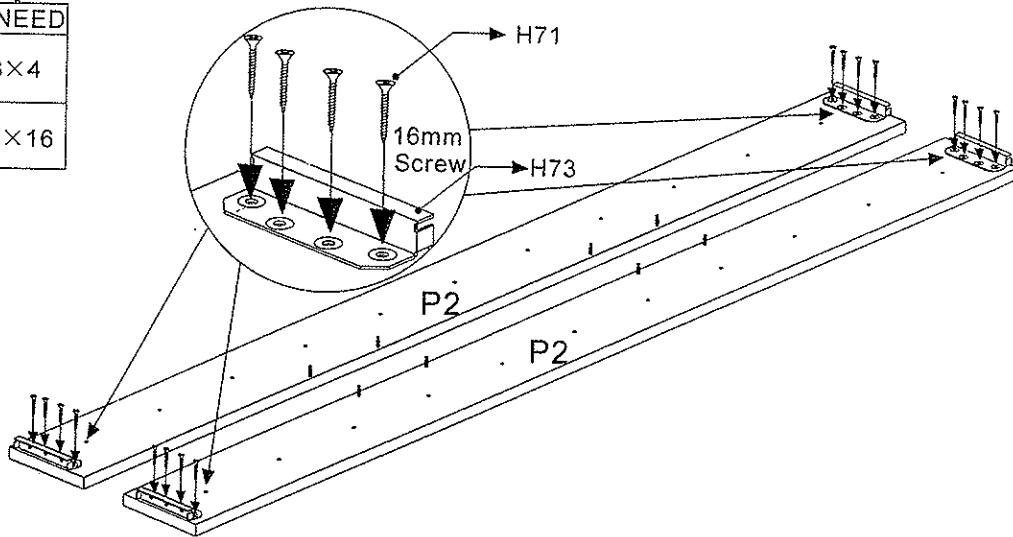
WHAT YOU NEED

	H73×4
	H71×16

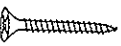

STEP 4.

WHAT YOU NEED

	H113×24
	H73×4
	H10×4
	H112×2

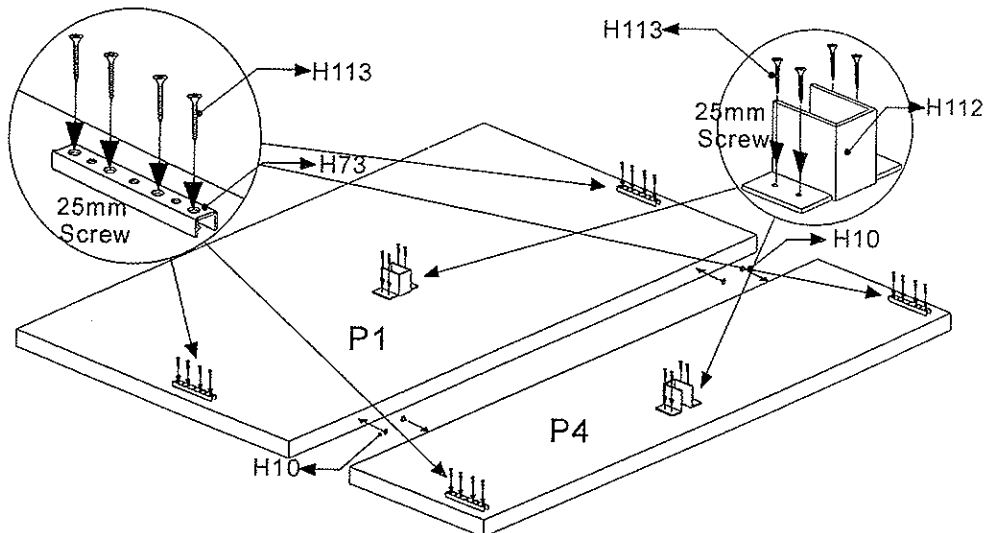

STEP 5.

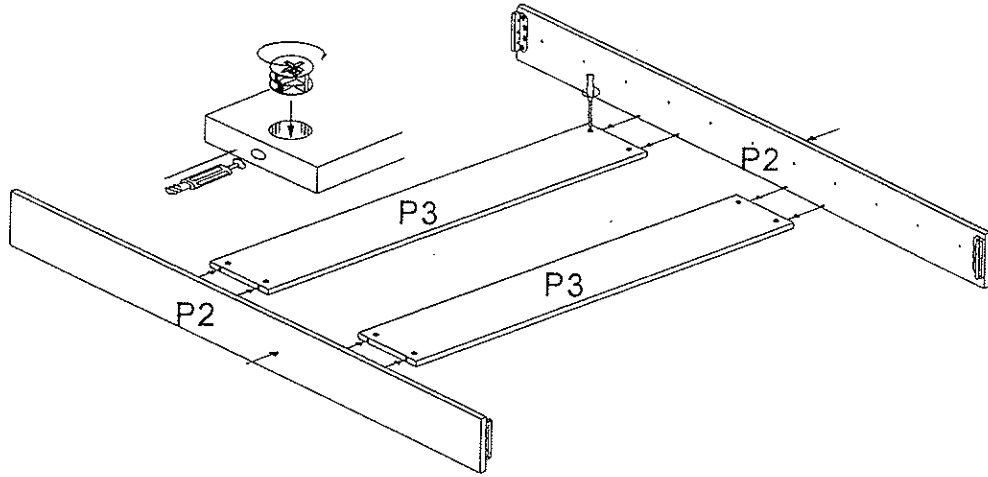

STEP 6.

WHAT YOU NEED	
	H72x1
	H73x2

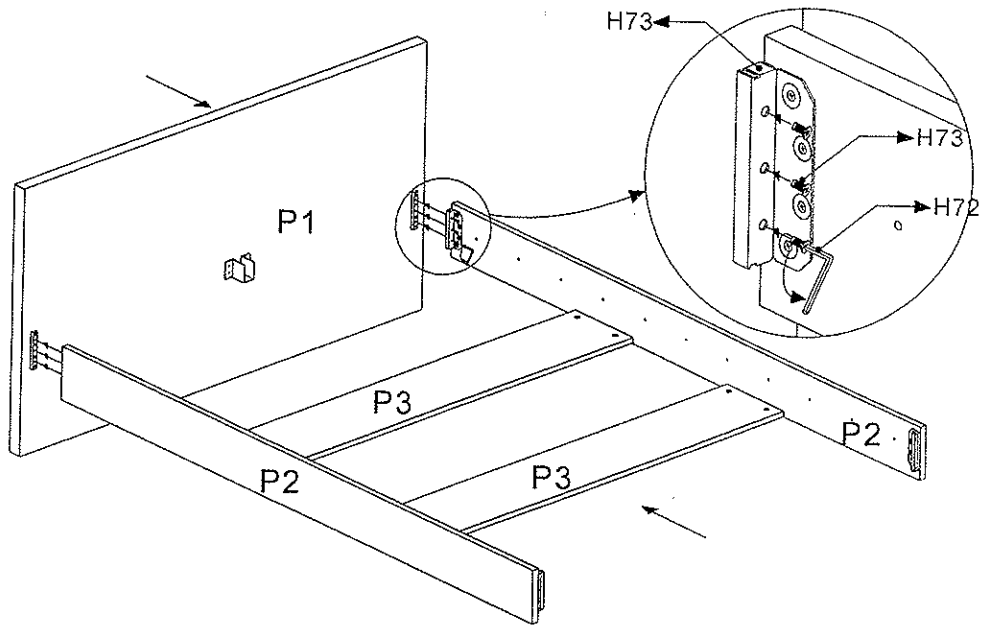

STEP 7.

WHAT YOU NEED	
	H72x1
	H73x2

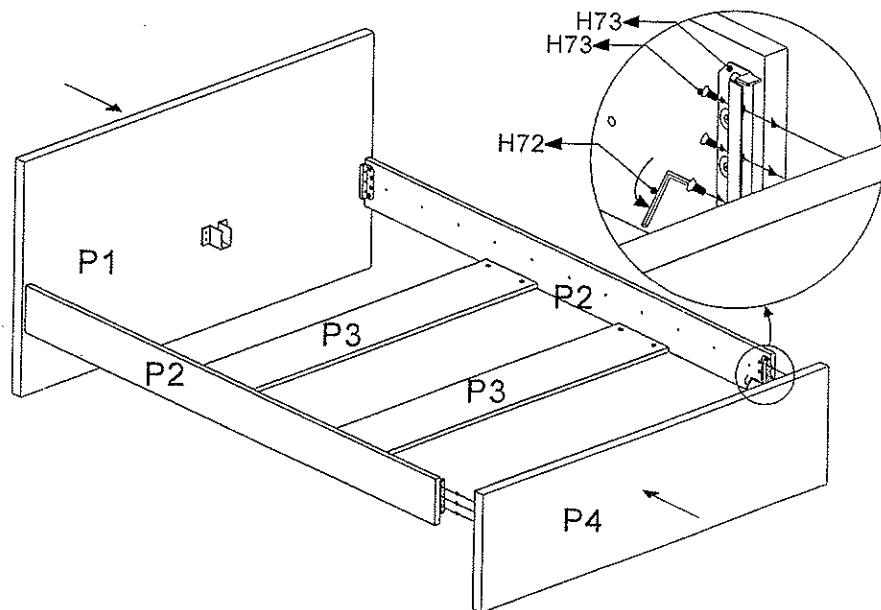

STEP 8.

WHAT YOU NEED

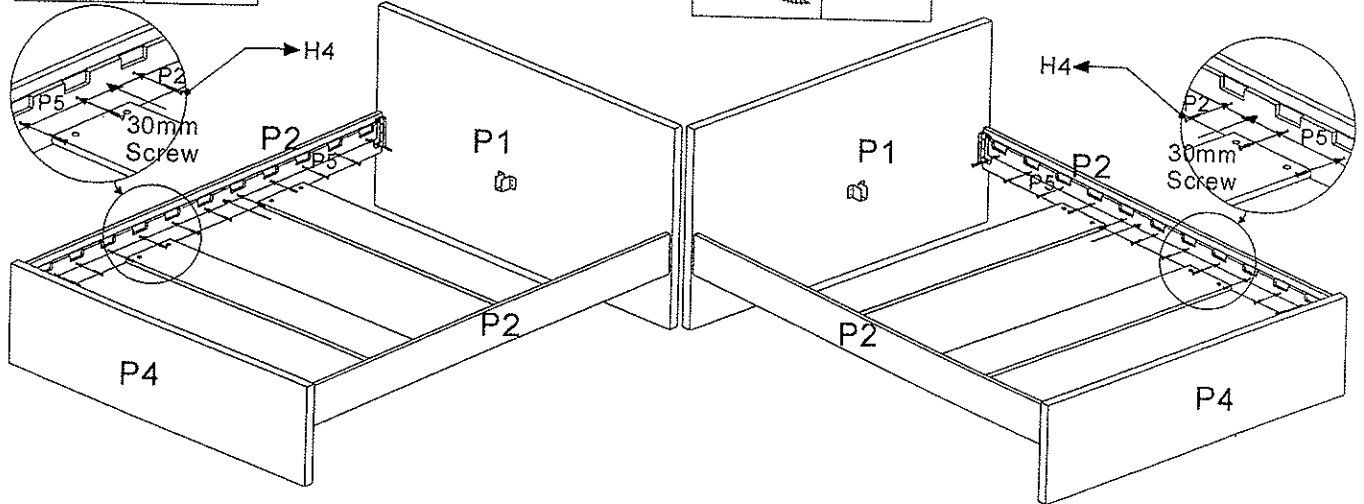
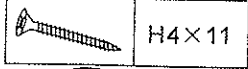

STEP 9.

WHAT YOU NEED

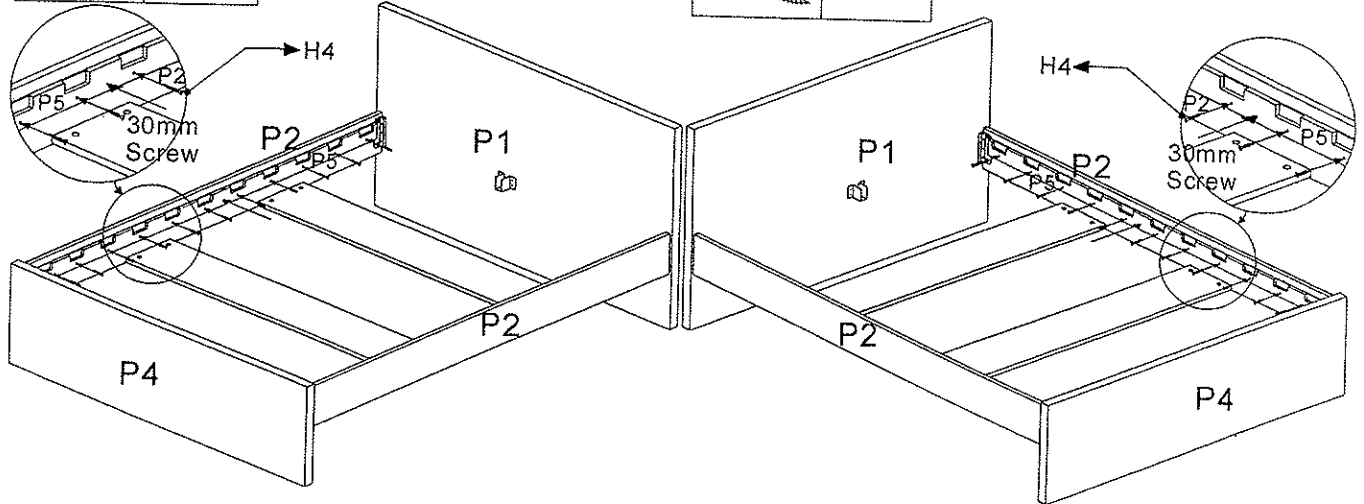
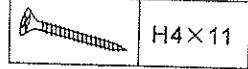

STEP 10.

WHAT YOU NEED

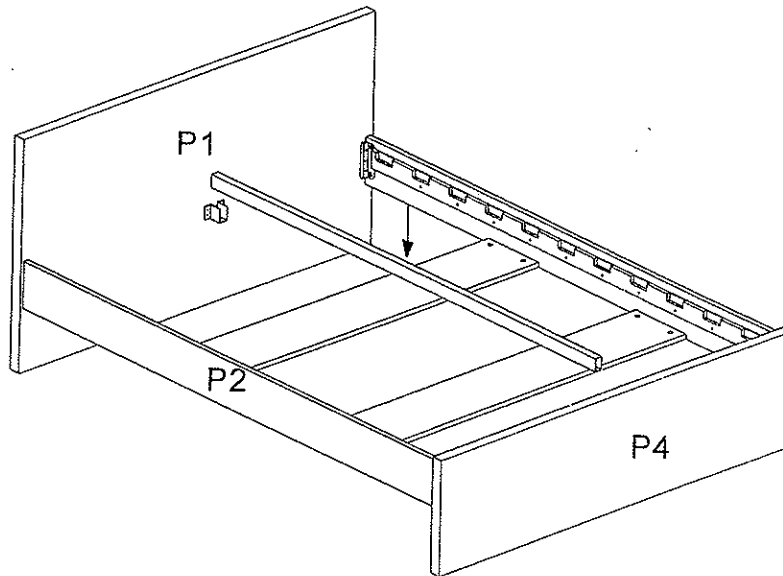
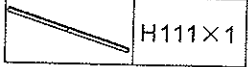

STEP 11.

